

- | Gear Pumps
- | Flow Measurement
- | Hydraulics
- | Valves

Gear type flow meters VC



Flow range	0.001 ... 3 750 l/min
Temperature range	-60 ... 210 °C
Maximum pressure	... 480 bar

In addition to our standard products, in close cooperation with our customers we have developed application-specific special solutions for fluidic measurement technology. The associated high-performance electronics process the signals supplied by the flow meter and ensure that processes are precisely monitored, regulated and controlled.

Benefit from our developments!
Get in touch with us. We would be glad to advise you.

Gear type flow meters

VC
Spheroidal cast iron / stainless steel



Gear type flow meters

VCA
Aluminium



Screw type flow meters

SVC
Spheroidal cast iron



Turbine flow meters

TM
Stainless steel



Valve position indicator

VOLUMEC



Electronics

ASR 30
Control unit



Electronics

ASR 14
Control unit

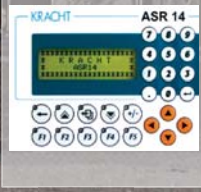

Electronics

AS 8
Control unit



Electronics

SD 1
Plug-in display



Exact with us

Applications and media

Pumpable liquids with a certain lubricity can be measured. These fluids include oils, brake fluid, diesel, Skydrol, paints, polyol + isocyanate, adhesives, resins, greases, silicones, paints, propellants, wax and solvents.

Automotive and Marine

- Test benches and plants
- Dosing and filling operating materials such as engine oils, brake fluids, antifreeze, preservatives, etc.
- Fuel consumption measurement
- Valve position indicator

Chemical Industry

- Flow rate and volume measurement in plants and plant systems
- Dosing and filling chemicals with and without abrasive fillers
- Measurement of extremely small amounts and microdosing
- Use in potentially explosive atmospheres

Paint and varnish industry

- Printing presses
- Painting systems
- Coating machines
- Dosing and filling
- Quantity, flow rate and consumption measurements
- Monitoring the mixing ratio

Hydraulics

- Flow and volume measurement
- Indirect, volumetric cylinder stroke measurement
- Cylinder synchronisation controllers
- Measurement, control, regulation of flow rates and volumes
- Test benches for pumps, motors and valves
- Filling and dosing
- Leakage monitoring
- Characteristic curve generation of hydraulic components
- Gear oil filling

Plastics Industry

- Mixing and dosing systems (single and multi-component systems)
- Consumption measurements
- Measurement and control of individual components and mixing ratios
- Flow rate and volume measurements
- Polyurethane (polyol and isocyanate)
- Low and high pressure dosing machines
- Dosing systems for pentane processing
- Block foam plants
- Paint dosages
- Premixing stations
- Hot melt adhesives

KRACHT[®]

Your fluid solution partner

Contents

Construction Function General product characteristics Approvals	6
Sensor versions	7
General characteristics Accuracy characteristics	8
Typical applications	9
Technical data	10 – 12
Type key	13
Electrical connections Signal characteristics	14
Electrical characteristics	15
IO-Link	16
Explosion-proof version (ATEX/IECEX)	17
Pressure drop charts	18 – 24
VC technical drawings overview	25
VC technical drawings (dimensions/weights)	26 – 34
Connecting plate technical drawings (dimensions/weights)	35 – 37
Flow measurement overview	38

Description

I Construction

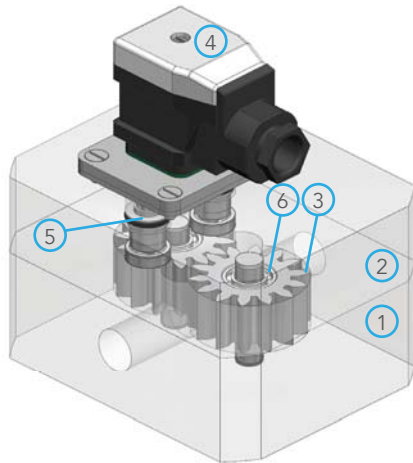

- 1 Housing
- 2 Cover
- 3 Gear
- 4 Plug
- 5 Sensor
- 6 Bearing

I General product characteristics

- High-precision measurements with excellent repeatability
- Maximal measurement resolution if used with encoder
- IO-Link technology available
- Wide measurement ranges with appropriate design sizes
- Application-optimised specification
- Low pressure drop
- Any flow direction
- Wide temperature range
- High working pressure
- Low noise emission
- Highly-dynamic measurements
- Explosion-proof versions ATEX/IECEx
- Electronics in EMV-compliant design
- RoHS-compliant

I Function

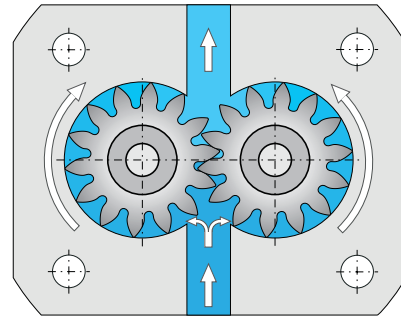

Consisting of two high-precision gears, the measuring unit is driven by the liquid flow based on the displacement principle. The gears run in an almost contactless manner in the measuring chamber. The bearing consists of ball and plain bearings.

Thanks to the measuring principle, there is no need for settling sections on the inlet and outlet side so that machines/plants can be designed to be more compact. All moving parts are lubricated by the measuring medium.

The gear movement is scanned in a contactless manner by the lid-mounted sensors. During the rotation of the measuring unit by one tooth pitch, a signal is generated per sensor that corresponds to the so-called geometric tooth volume V_{gz} . The dual-channel scanning facilitates a higher measuring resolution and detection of the direction of flow.

Alternatively available encoder specifications deliver maximal measurement resolution.

Approvals

	Description	Country
	EU compliance – EMV – pressure equipment – RoHS	European Union
	EAC EMV guideline	Eurasian Economic Community
	GOST metrology, measurement technology	Russia
	IO-Link	International

Description

I Standard version



The standard versions come with an integrated pre-amplifier which converts the pulses from the magnetic sensors into square-wave signals which are then computed by an electronics into specific measurement values.

The optionally available remote-electronics version is designed to handle extreme temperature ranges.

I Encoder version with maximised measurement resolution



Compared with standard sensors, encoders are capable of generating considerably more pulses, thus increasing measurement resolution by orders of magnitude. Encoder-equipped SVC flow meters generate up to 2 500 pulses per revolution and can recognise the direction of flow.

Encoders, like the standard versions, send square-wave signals to the electronics.

I IO-Link version with internal calculation of measured values



VC flow meters with IO-Link technology are based on standard VCs with one or two sensors. Unlike standard or encoder versions which always send a square-wave signal to the electronics, IO-Link devices have the added capability of internally computing concrete measurement values. Therefore, these flow meters lend themselves for use in classic PLC and in IO-Link infrastructures.

Please see page 16 for details.

Technical data

I General characteristics

Nominal sizes	0.025 · 0.04 · 0.1 · 0.2 · 0.4 · 1 · 3 · 5 · 12 · 16
Type of connection	plate mounting (P) / pipe connection (R)
Mounting position	any
Flow direction	any
Typical measurement accuracy	+/- 0.3% from a viscosity of 20 mm ² /s
Maximum pressure	0.025 · 0.04 · 0.1 · 0.2 · 0.4 · 1 · 12 · 16 ... 480 bar 3 · 5 ... 480 bar in K3 specification (in all other cases ... 350 bar)
Maximum permissible pressure loss	16 bar
Ambient temperature	-60 ... 150°C
Media temperature	-60 ... 210°C
Viscosity	... 2 500 000 mm ² /s
Sound pressure level	... 65 dB(A)

I Accuracy characteristics

- The indicated measurement accuracy refers to the pulse volume, i.e. the percentage variance applies to the latest measurement value.
- The measurement accuracy is up to +/- 0.3% of the measured value by default.
- Repeatability is +/- 0.05% in stable conditions.
- The measurement accuracy tests performed can be traced to DAkkS (Deutsche Akkreditierungsstelle, German Accreditation Body).
- The measurement accuracy characteristics indicated by KRACHT is confirmed by DAkkS.
- A calibration is possible on request. The result of this calibration will be documented in the form of a measurement accuracy characteristic.

Typical measurement accuracy characteristic

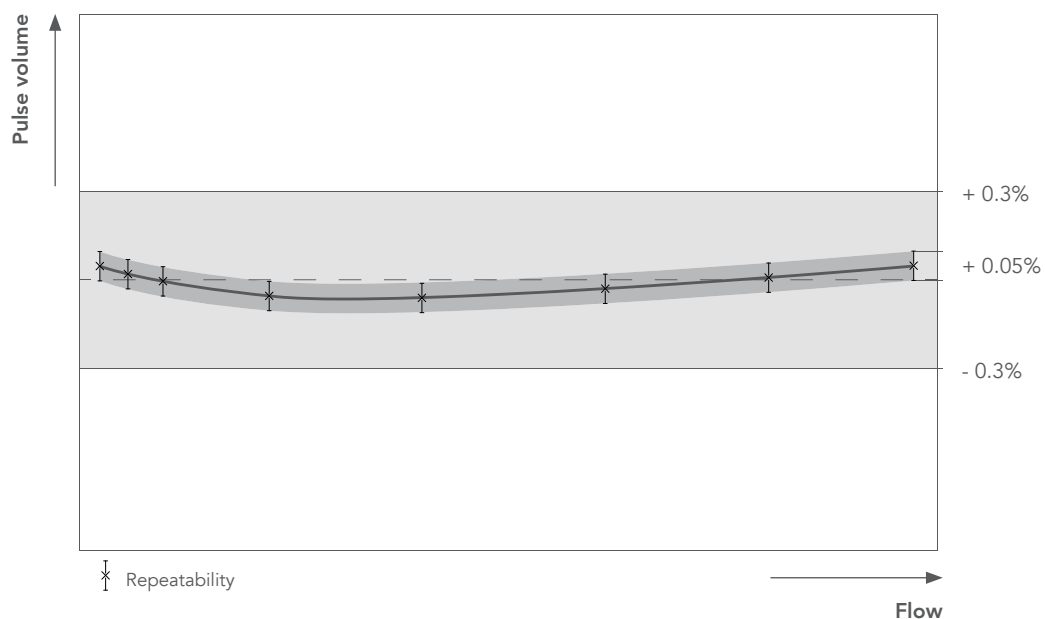

Technical data

I Application examples

Specifications (type key ID for bearing and material)	Typical media	Typical media characteristics	Typical application of the flow/ volume measurement
K1	Oil Braking fluid Diesel Skydrol	lubricating fluids low to medium viscosity	Hydraulic systems Test bench construction Cylinder stroke measurement
C1	Gear oil	lubricating fluids medium viscosity	oil filling (metering systems)
G1	offset ink polyol isocyanate glue resin silicone	lubricating fluids medium to high viscosity	consumption measuring (printing machines)
G2	polyol isocyanate glue resin silicone	poor lubricating fluids medium to high viscosity	Ratio control (2-component systems)
K2	clear varnish cavity sealing wax	lubricating fluids low to medium viscosity	dosing control (paint-spray lines) test bench construction
H2	urea (adBlue) solvents petrol	poor lubricating fluids low viscosity	flow measurement (paint-spray lines) test bench construction dosing
K3	oil braking fluid diesel Skydrol	lubricating fluids low viscosity	applications of up to 480 bar for nominal sizes 3 and 5
K4	oil diesel water	low viscosity	flow measurement

Technical data

I Overview

Specifications (type key ID for bearing and material)	K1	K2	G1	G2	C1	H2	K3	K4
Bearing	ball bearing	ball bearing	carbide plain bearing	carbide plain bearing	ball bearing (high tolerance)	hybrid ball bearing	ball bearing	ball bearing
Material: housing	spheroidal cast iron GJS-400-15	stainless steel 1.4404	spheroidal cast iron GJS-400-15	stainless steel 1.4404	spheroidal cast iron GJS-400-15	stainless steel 1.4404	spheroidal cast iron EN-GJS-400-600	aluminium 3.2315
Material: gears	steel 1.7131	stainless steel 1.4462	steel 1.7131	stainless steel 1.4462	steel 1.7131	stainless steel 1.4462	steel 1.7131	stainless steel 1.4462
Type of connection	P	P / R	P	P / R	P	P / R	P	R
Permissible particle size in pumped medium	20 µm	20 µm	30 µm	30 µm	30 µm	20 µm	20 µm	20 µm
Medium temperature* in °C	-40 ... 210	-60 ... 210	-40 ... 80	-40 ... 80	-40 ... 210	-40 ... 210	-40 ... 210	-10 ... 80
Maximum pressure in bar	480	480	480	480	480	480	480	200

* See selection guide on page 12

I Available electronics versions

Standard	•	•	•	•	•	•	•	•
High-temperature	•	•	–	–	•	•	•	–
ATEX	•	•	•	•	•	•	•	•
IO-Link	•	•	•	•	•	•	•	•
Encoder	•	–	•	–	–	–	–	–
High-temperature PLUS	•	•	–	–	–	•	•	–
ATEX high-temperature PLUS	•	•	–	–	–	•	•	–
Low-temperature	–	•	–	–	–	–	–	–

I Operating characteristics

Nominal size	Resolution *	Encoder Type 512 **	Starting point	Measuring range								
				pulse/l	pulse/l	l/min	l/min					
0.025	40,000	–	0.001	0.008 ... 2	0.008 ... 2	–	0.02 ... 2	–	0.008 ... 2	–	–	
0.04	25,000	673,684	0.004	0.02 ... 4	0.02 ... 4	–	–	–	0.02 ... 4	–	–	
0.1	10,000	–	0.008	0.04 ... 8	0.04 ... 8	0.04 ... 8	–	–	0.04 ... 8	–	–	
0.2	4,081	149,271	0.01	0.16 ... 16	0.16 ... 16	0.16 ... 16	0.16 ... 16	0.16 ... 16	0.16 ... 16	–	0.2 ... 12	
0.4	2,500	–	0.01	0.2 ... 40	–	0.2 ... 30	0.2 ... 30	–	–	–	–	
1	965	35,301	0.02	0.4 ... 80	0.4 ... 80	0.3 ... 60	0.3 ... 60	0.4 ... 80	0.4 ... 80	–	–	
3	333	–	0.03	0.6 ... 160***	0.6 ... 160***	0.6 ... 100***	0.6 ... 100***	0.6 ... 160***	–	0.6 ... 160	–	
5	191	–	0.04	1 ... 250***	1 ... 250***	1 ... 160***	1 ... 160***	1 ... 250***	–	1 ... 250	–	
12	83	–	0.1	2 ... 600	–	–	–	–	–	–	–	
16	62	–	0.2	3 ... 700	–	–	–	–	–	–	–	

* It is possible to quadruple the resolution by employing both measuring channels.

** More sensor resolutions available on request.

*** maximum pressure 350 bar

Technical data

I Encoder version resolution

Nominal size	Sensor resolution*	Pulse volume	Resolution	Measured value resolution 4-fold**	Pulse frequency with Q_{max}
	pulse/rev	cm ³ /pulse	pulse/l	pulse/l	Hz
0.04	512	0.001484	673,684	2,694,737	44,912
	2,500	0.000304	3,289,474	13,157,896	219,298
0.2	512	0.006699	149,271	597,084	39,806
	2,500	0.001372	728,863	2,915,452	194,363
1	512	0.028328	35,301	141,204	47,067
	2,500	0.005802	172,366	689,464	229,822

* More sensor resolutions available on request.

** Resolution with both measuring channels and 4-fold evaluation

I Sealing elements and electronics temperature tolerance

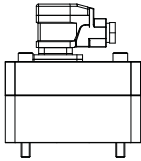
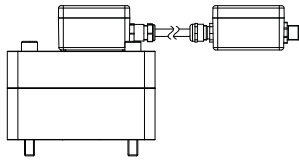
Versions with integrated electronics								Remote-electronics versions			
Version with appliance socket (Hirschmann) $T_{amb} = -40^* \dots 80^{\circ}C$								$T_{amb} = -60^* \dots 150^{\circ}C \quad -40 \dots 80^{\circ}C$			
											
Electronics version	Standard	Reduced supply voltage 12 V	High temperature	ATEX version	IO-Link	without pre-amplifier	Encoder**	High-temperature PLUS	ATEX version High-temperature PLUS	Low-temperature	
Type key ID	S	R	H	X	L	V	E	K	KX	T	
Sealing material	Medium temperature in °C										
FKM					-15 ... 80	-30 ... 80			-		
EPDM	-40 ... 120		-40 ... 150		-30 ... 80		-40 ... 120	-20 ... 80	-		
FEP					-30*** ... 80				-40 ... 210	-30*** ... 180	-
FFKM	-15 ... 120		-15 ... 150		-15 ... 80		-15 ... 120	-15 ... 80	-15 ... 210	-15 ... 200	-
FVMQ	-								-		-60 ... 200

* For ATEX/IECEX: T_{amb} min FKM = -15 °C
 T_{amb} min EPDM = -30 °C
 T_{amb} min FEP = -30 °C
 T_{amb} min FFKM = -15 °C

** Only for K1 and G1

*** Devices produced up to and including 2019 can be used at temperatures of up to -15°C.

Selection guide

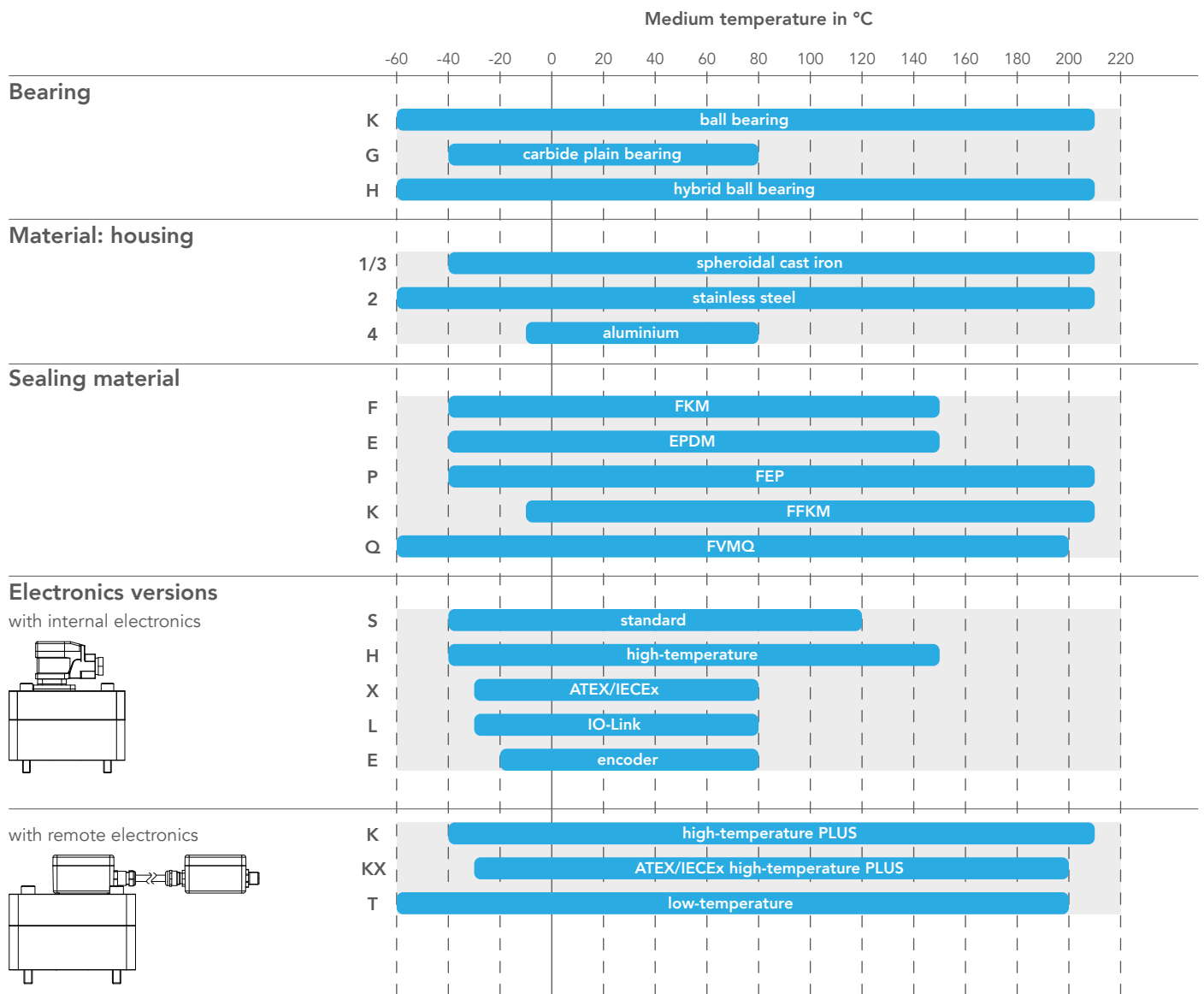

I Example: determination of temperature range

VC 1 K 1 F 1 P 2 S H

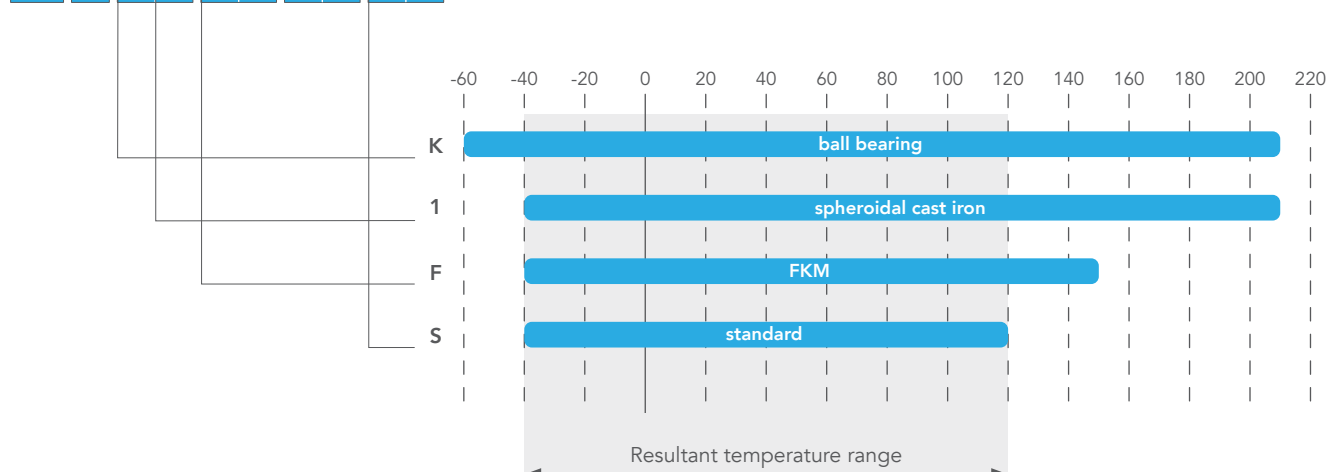

Type key

Example

VC	1	K	1	F	1	P	2	S	H
1	2	3	4	5	6	7	8	9	11

1 Product									
2 Nominal size									
0.025	0.04	0.1	0.2	0.4	1	3	5	12	16
3 Bearing									
K		H			C			G	
ball bearing		hybrid ball bearing			ball bearing, high tolerance			carbide plain bearing	
4 Material									
1			2			3			4
housing spheroidal cast iron GJS-400 gears steel			housing stainless steel gears stainless steel			housing spheroidal cast iron GJS-600 gears steel			housing aluminium (only nominal size 0.2)
5 Sealing									
F		E			P		K		Q
FKM		EPDM			FEP		FFKM		FVMQ
6 Surface									
1			2				3		
standard (coated)			Skydrol-resistant coating				without coating		
7 Connection type									
P					R				
plate mounting					pipe connection				
8 Sensors									Note
2	2 sensors								
1	1 sensor								
3	without sensors								
4	2 sensors vibration-proof/condensation-proof								
5	encoder only nominal sizes 0.01 · 0.04 · 0.2 · 1								Pos. 9: only with E
9 Electronic versions (pre-amplifier)		Voltage	Media temperature	Conversion	Note				
S	standard	24 V	-40 ... 120°C	internal					
H	high-temperature	24 V	... 150°C	internal					
K	high-temperature PLUS	24 V	... 210°C	external					
T	low-temperature	24 V	-60°C ...	external					
X	ATEX/IECEX (isolating switching amplifier to be ordered separately)		... 80°C	internal	Pos. 11: only with H				
KX	ATEX/IECEX high-temperature PLUS		... 200°C	external	Pos. 11: only with V				
R	reduced supply voltage	12 V	... 120°C	internal					
L	IO-Link	9 ... 36 V	... 80°C	internal					
V	without pre-amplifier		... 120°C						
E	encoder	11 ... 30 V	... 100°C	internal					
10 Cable length									
without cable between flow meter and electronics		2			5			10	
		with 2 m cable			with 5 m cable			with 10 m cable	
11 Electric connection (plug and pre-amplifier case)									
H	appliance socket (Hirschmann)		standard						
M	appliance socket (Hirschmann)		with M12x1 4-pole connection						
K	aluminium connection box		with M12x1 4-pole connection						
C	aluminium connection box		with Cannon plug KPTC						
E	aluminium connection box		with M12x1 4-pole connection, ext. electronics can be disengaged						
V	without								
512	encoder with 512 pulse/rev		with M12x1 4-pole connection						
2500	encoder with 2500 pulse/rev		with M12x1 4-pole connection						

Electronics

I Electric connections

Standard and high-temperature version

High-temperature PLUS and low-temperature version

Connection plug arrangement (M12x1 4-pole round connector)

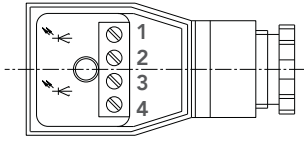

1: U _B (brown)
2: Channel 1 (green)
3: Channel 2 (yellow)
4: 0 Volt (white)

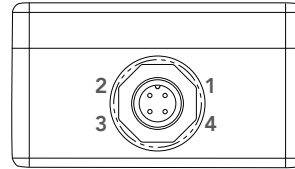

1: U _B (brown)
2: Channel 1 (white)
3: 0 Volt (blue)
4: Channel 2 (black)

Encoder version

Connection plug arrangement (M12x1 metal/4-pole round connector)

Cannon version

Connection plug arrangement

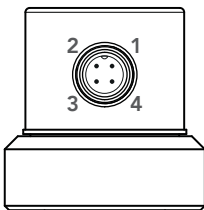

1: U _B
2: channel 1
3: 0 Volt
4: channel 2

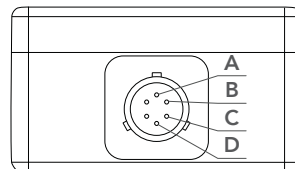

A: U _B (brown)
B: Channel 1 (green)
C: Channel 2 (yellow)
D: 0 Volt (white)

IO-Link version

Connection plug arrangement (M12x1 metal/4-pole round connector)

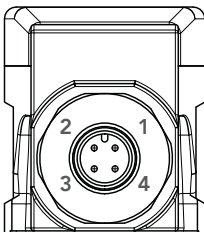

	IO-Link mode	SIO mode
1: brown	U _B	
2: white	I/Q	Channel 1
3: blue	0 Volt	
4: black	C/Q	channel 2

I Signal characteristics (standard, high-temperature, encoder, IO-Link versions in SIO mode)

The pre-amplifier-generated square-wave signal enables application-specific resolutions. Standard resolution means that the electronics will process one pulse from a channel/sensor per cycle time (rising signal edge in channel I). In contrast, the 4-fold evaluation uses the maximal pulse rate per cycle time, allowing for a resolution that is four times as high as in the standard evaluation. All characteristics of the signal (rising and falling signal edge of both sensors/channels) are exploited in the evaluation.

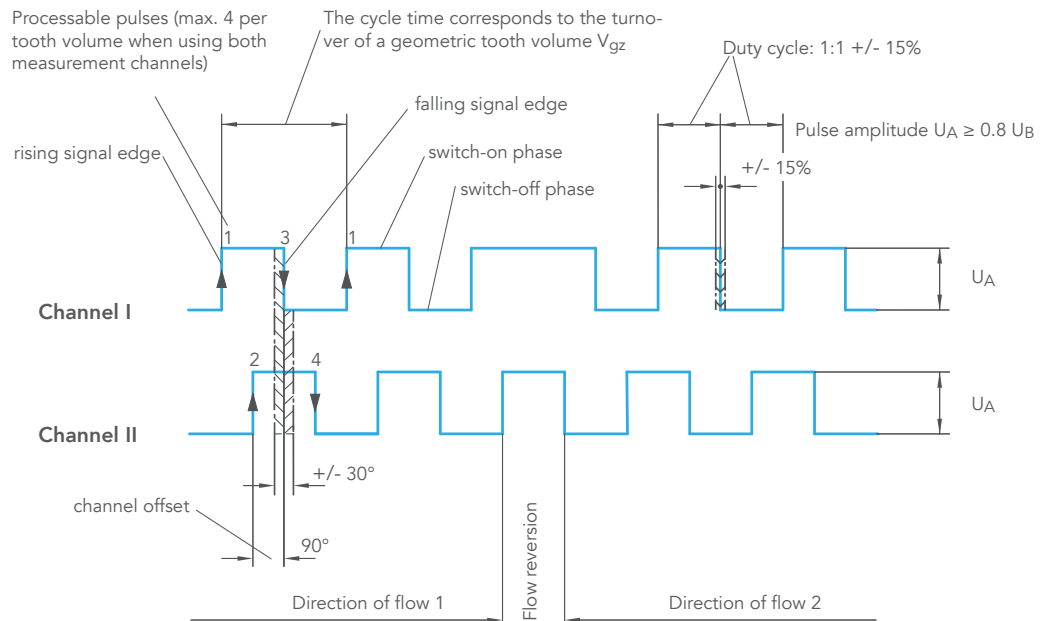

Electronics

I Standard versions electrical characteristics

Number of measuring channels	1 or 2
Working voltage U_B	24 V +/- 20% or 12 V +/- 20% for versions with reduced supply voltage
Pulse amplitude U_A	$\geq 0.8 U_B$
Pulse shape with symmetrical output signal	Square wave, duty factor/channel 1:1 \pm 15%
Signal output	PNP / NPN
Pulse offset between the two channels	$90^\circ \pm 30^\circ$
Power requirement $P_{b \max}$	0.9 W
Output power / channel $P_{a \max}$	0.3 W short circuit-protected
Protection rating	IP 65

I Encoder versions electrical characteristics

Number of measuring channels	2
Working voltage U_B	11 ... 30 V
Pulse amplitude U_A	$Min_{High} \geq U_B - 3 V$ $Max_{Low} \leq 2,5 V$
Pulse shape with symmetrical output signal	Square wave, duty factor/channel 1:1 \pm 15%
Signal output	Push-Pull
Pulse offset between both channels	$90^\circ \pm 30^\circ$
Maximum load	+/- 30 mA
Power consumption	standard 45 mA maximum 150 mA
Protection rating	IP 65

I IO-Link versions electrical characteristics

	IO-Link mode	SIO mode
Number of measuring channels	1 or 2	
Working voltage U_B	9 ... 36 V	
Pulse amplitude U_A	$Min_{High} \geq U_B - 2 V$ $Max_{Low} \leq 2 V$	
Pulse shape with symmetrical output signal	–	Square wave, duty factor/ channel 1:1 \pm 15%
Signal output	active pull \pm 200 mA	
Pulse offset between the two channels	–	$90^\circ \pm 30^\circ$
Power requirement $P_{b \max}$	1 W	
Protection rating	IP 65	

Electronics

I IO-Link

Thanks to its international standardisation (IEC 61131-9), the IO-Link technology offers point-to-point connectivity with continuous monitoring between any desired control layer and the VC-IO-Link assembly. Handling and startup is made easy by the associated IODD (IO Device Description) file.

The VC-IO-Link assembly directly delivers all measured values with units. In the preset SIO mode (standard input output), the volume counter gives square-wave signals if the IO-Link mode is not enabled by an IO-Link master. This provides downward compatibility of the VC-IO-Link assembly with the standard square-wave signal (see page 14).

IO-Link connection plug

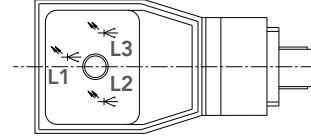

	IO-Link mode	SIO mode
L1 green	Flashing at 1/s	Continuous light, ready for operation
L2 red	Channel 1 gear detected = LED on gear not detected = LED off	
L3 red	Channel 2 gear detected = LED on gear not detected = LED off	

IO-Link characteristics

Name	VC
Manufacturer ID	0x0524
Device ID	0x000001
Name of manufacturer	Kracht GmbH
IO-Link connection plug	V1.1
Bit rate	COM3 / 230.4 kbit/s
Minimum cycle time	500µs
SIO mode supported	Yes
Indexed service data unit used (IS DU)	Yes
Data storage (DS) possible	Yes

I Communication of the IO-Link assembly

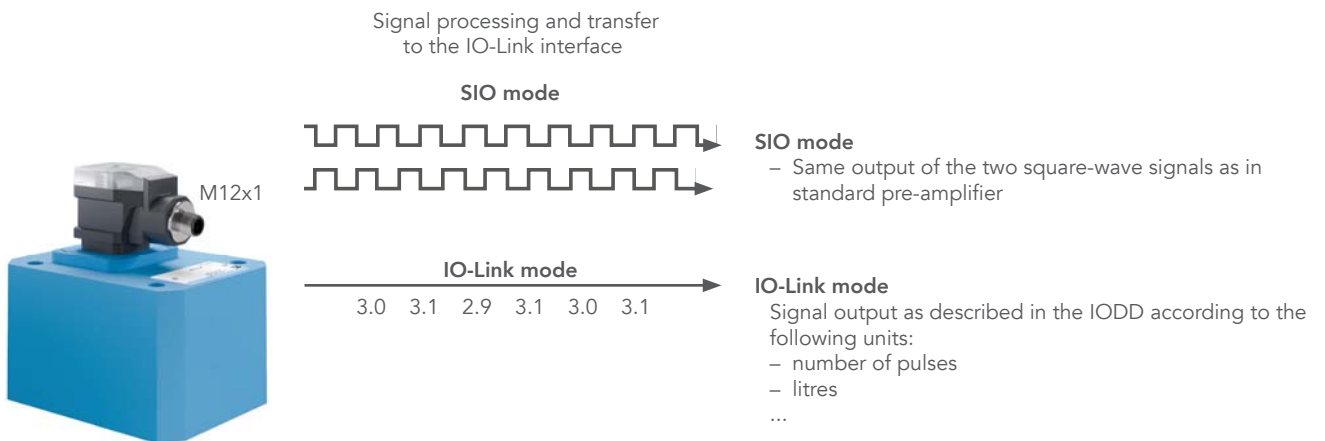

Explosion-proof version (ATEX/IECEX)

I Function

- All gear type flow meters are available as explosion-proof versions according to ATEX and IECEx certification.
- The explosion-proof version consists of the gear type flow meter (intrinsically safe electric gear) and the switching amplifier K 130 (accessory electric gear). This layout meets the ignition protection type "intrinsic safety".
- The gear type flow meter is installed in the explosive atmosphere.
- The switching amplifier K 130 is assembled in the safe atmosphere.
- The gear type flow meter is electrically connected with the switching amplifier. The switching amplifier analyses the sensor signals coming from the gear type flow meter and converts them into square-wave signals.
- It is prohibited to deploy the gear type flow meter in explosive atmospheres without switching amplifier.
- The cable between the gear type flow meter and switching amplifier may be up to 400 m long.
- The switching amplifier features LEDs to monitor for line breakage / short circuit, channel switching state, and voltage supply.

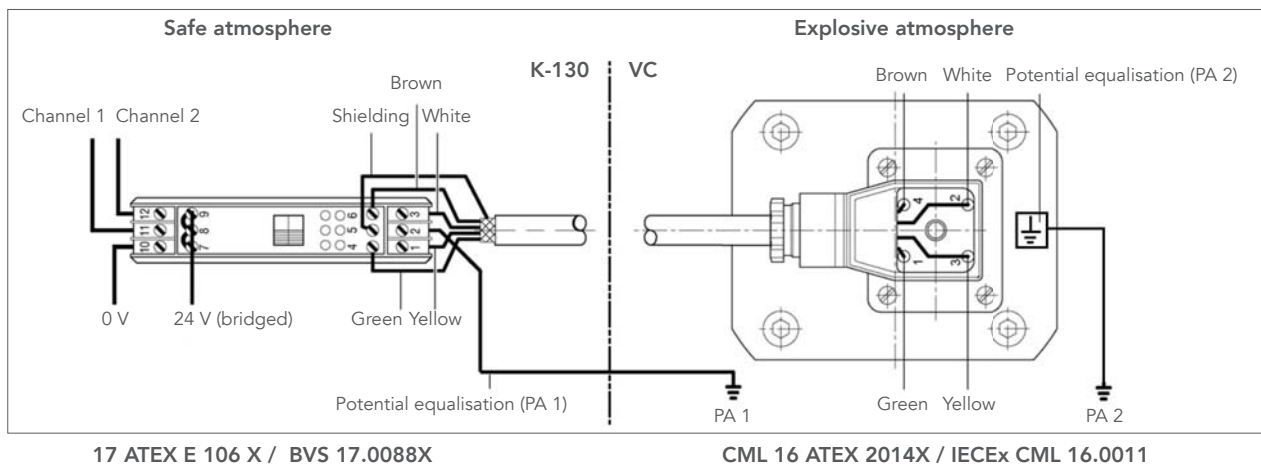

Notes

This drawing only serves as an example for the connection of the sensors to the isolating switching amplifier K 130. Observe the applicable standards when assembling a plant in an explosive atmosphere.

Ignition protection marking (device-dependent)

⊕ II 2G Ex ia IIC T4 Gb

⊕ II 2D Ex ia IIIC T135 °C Db

I Switching amplifier K-130 technical characteristics

Supply	
Supply voltage terminal 7 (L+), terminal 10 (L-)	DC 24 Volt +/- 20%
Output (not intrinsically safe / nominal data of terminals 9, 12, 8, 11)	
Electronic outputs	electrically isolated via photocoupler
Signal level 1-signal	Output voltage > 15 V
Signal level 0-signal	Output voltage ≤ 5 V
Ambient conditions	
low threshold temperature	248 K (- 25°C)
high threshold temperature	333 K (+ 60°C)
Mechanics	
Dimensions	114.5 x 99 x 22 mm
Mounting	can be snapped on to 35mm sectional rail, DIN EN 60715

Pressure drop

I Ball-bearing versions Parameter: Viscosity in mm²/s

VC 0.025

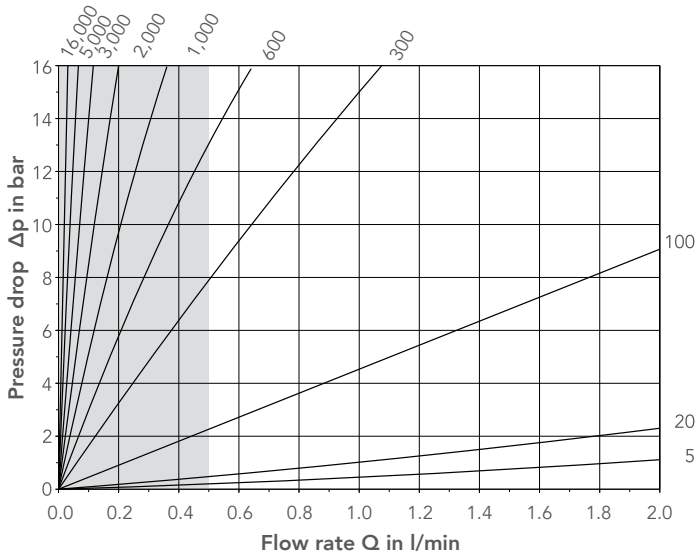

VC 0.025 (section)

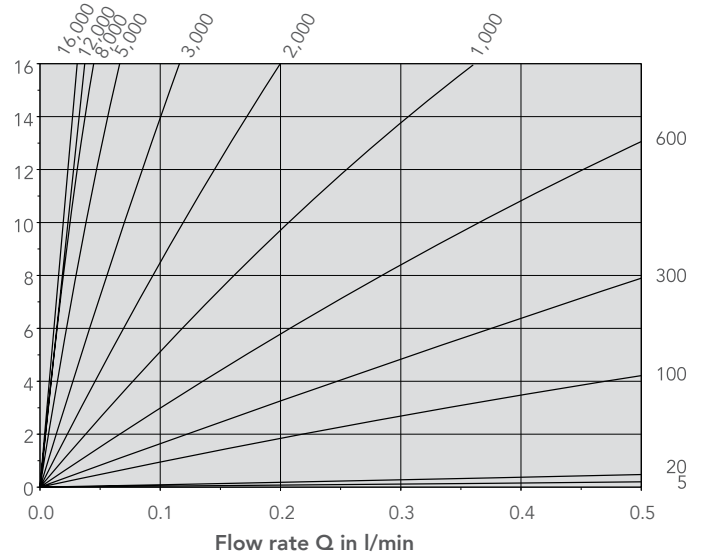

VC 0.04

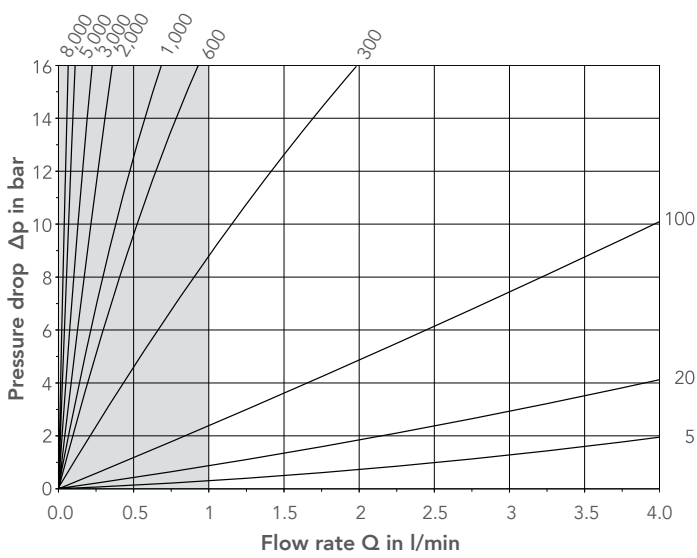

VC 0.04 (section)

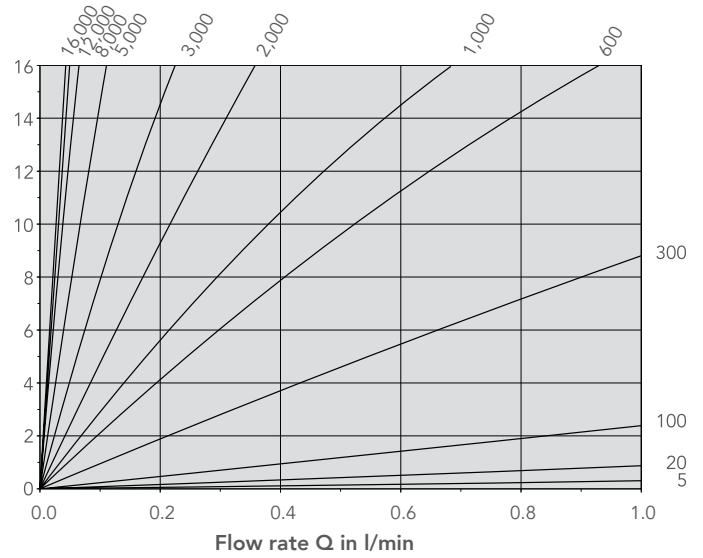

VC 0.1

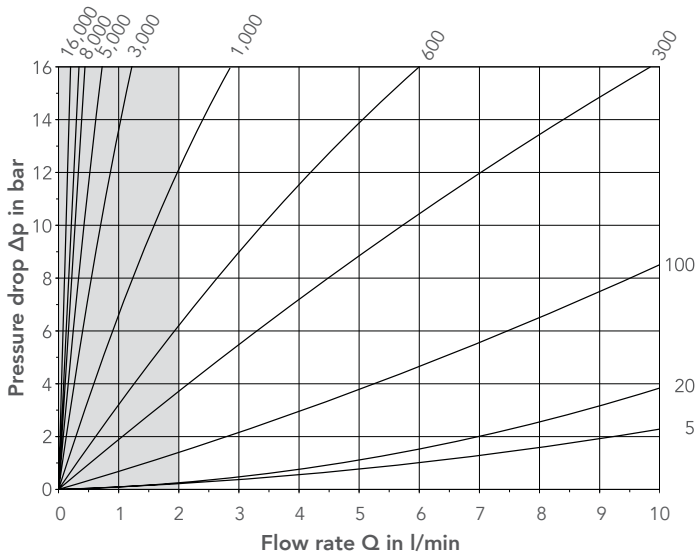

VC 0.1 (section)

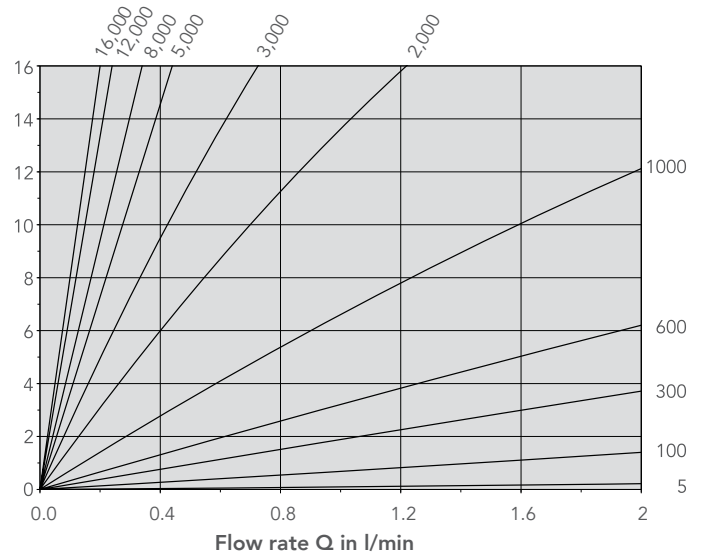

Pressure drop

I Ball-bearing versions Parameter: Viscosity in mm^2/s

VC 0.2

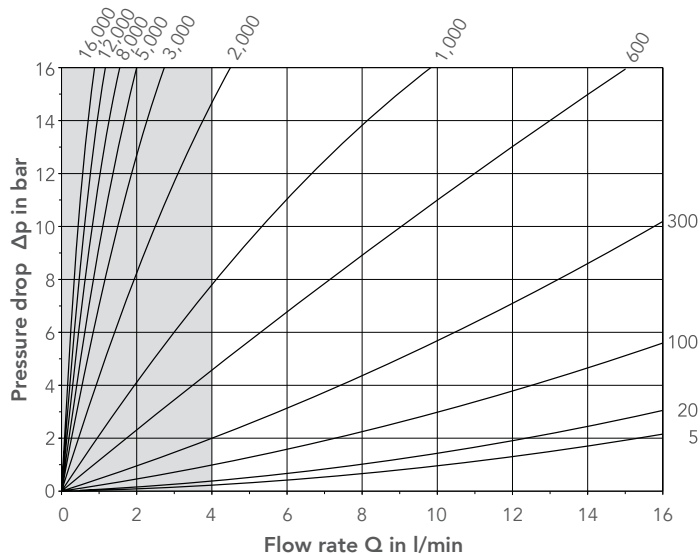

VC 0.2 (section)

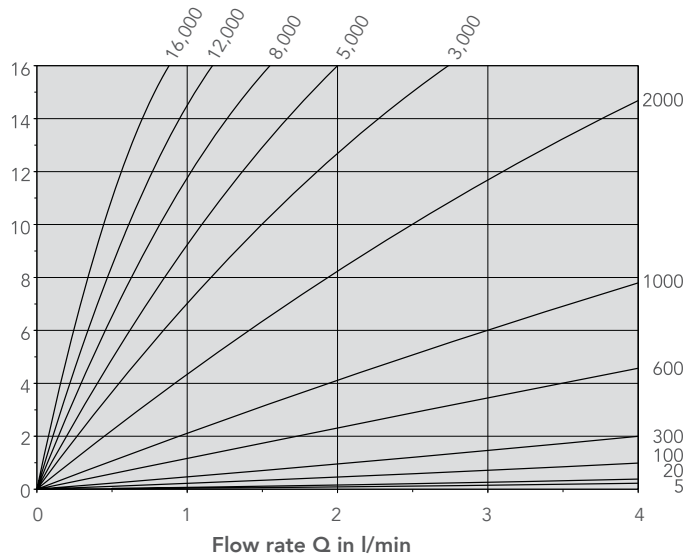

VC 0.4

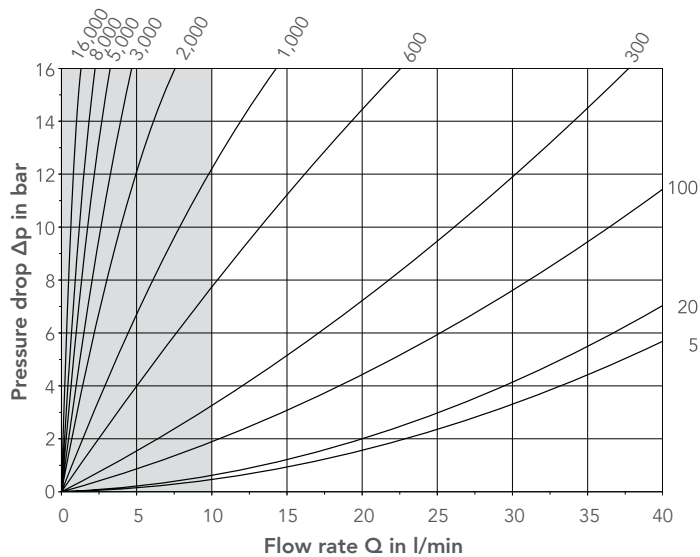

VC 0.4 (section)

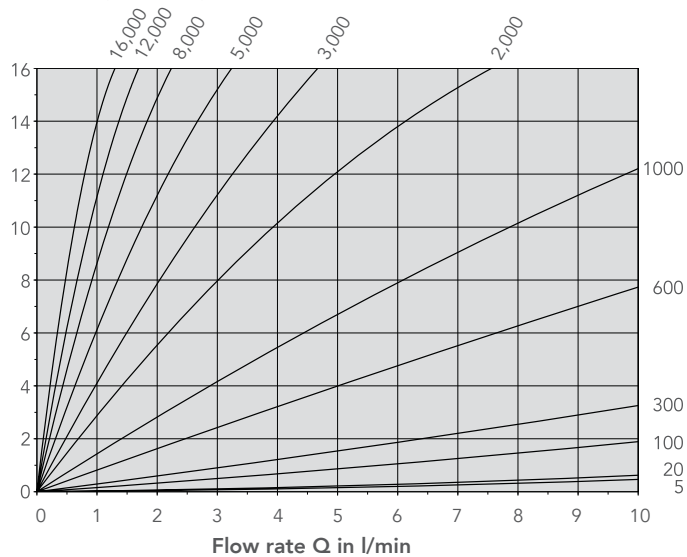

VC 1

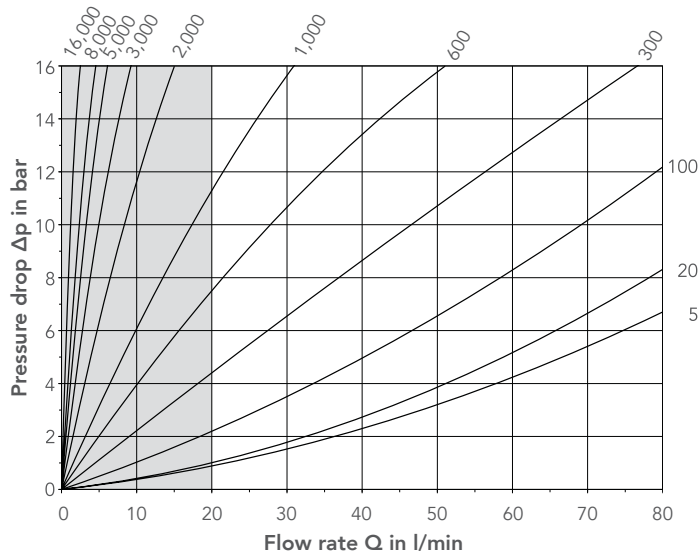

VC 1 (section)

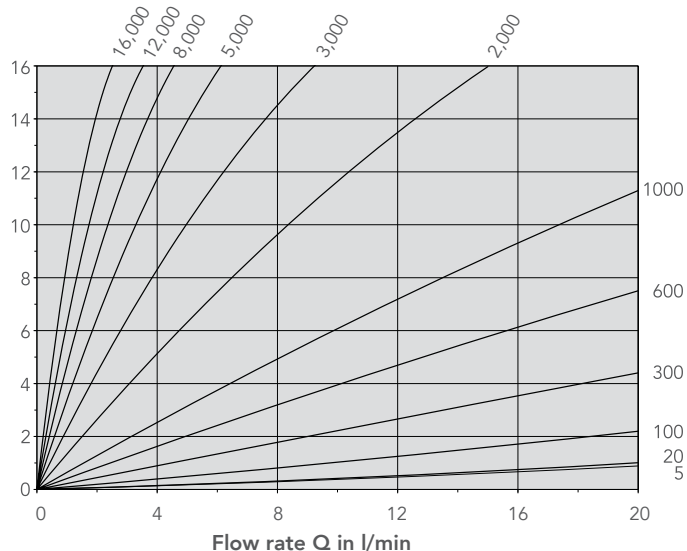

Pressure drop

I Ball-bearing versions Parameter: Viscosity in mm²/s

VC 3

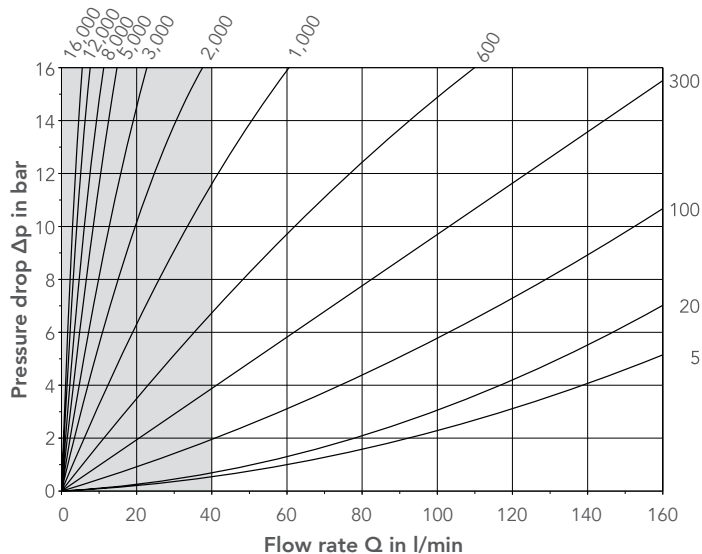

VC 3 (section)

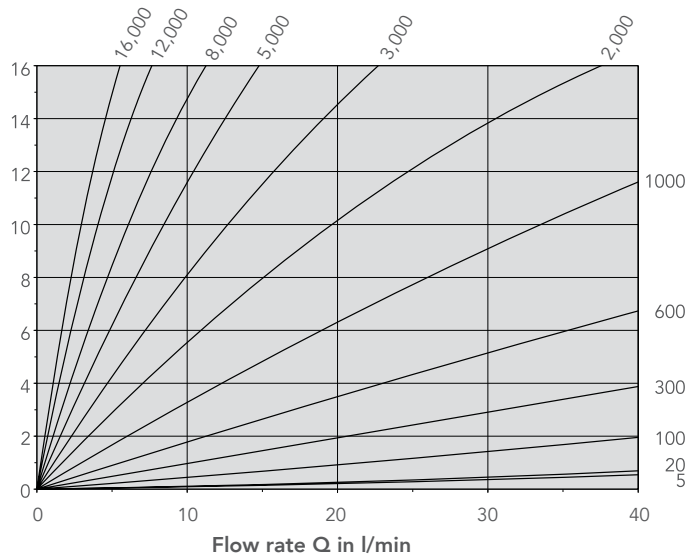

VC 5

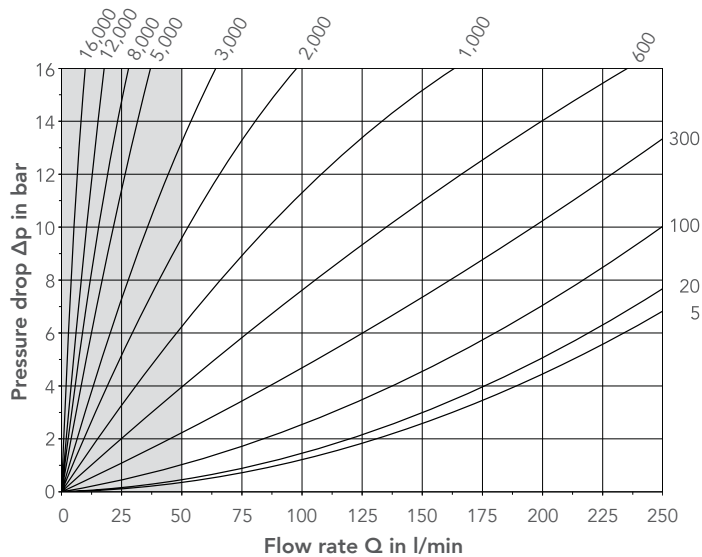

VC 5 (section)

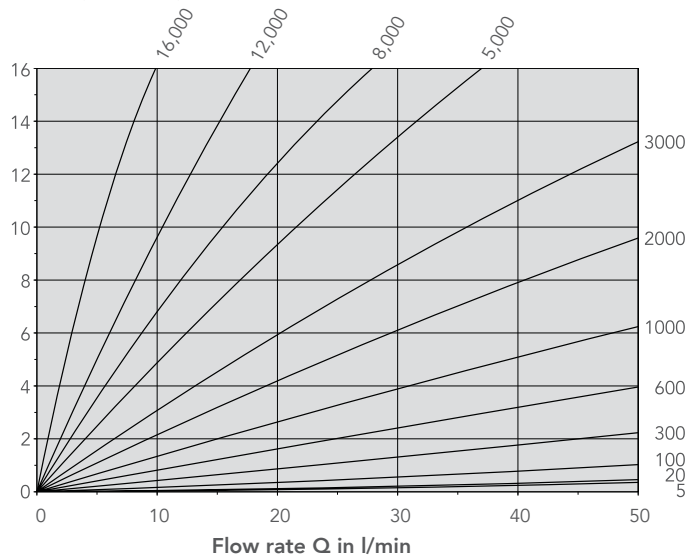

VC 12

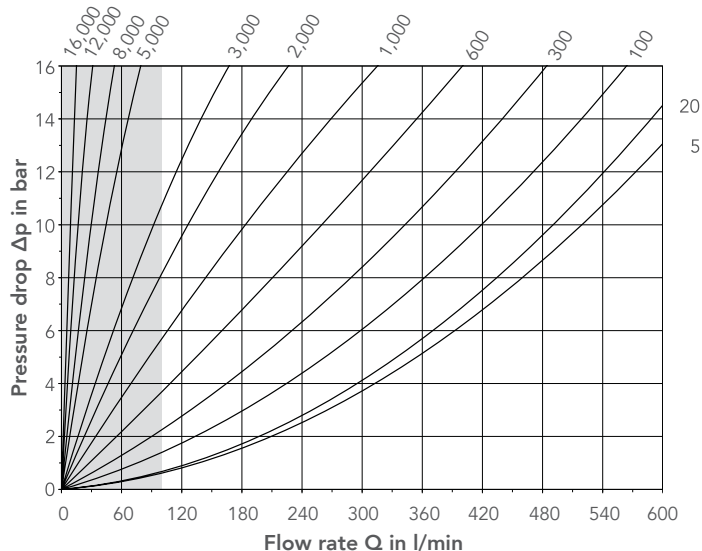

VC 12 (section)

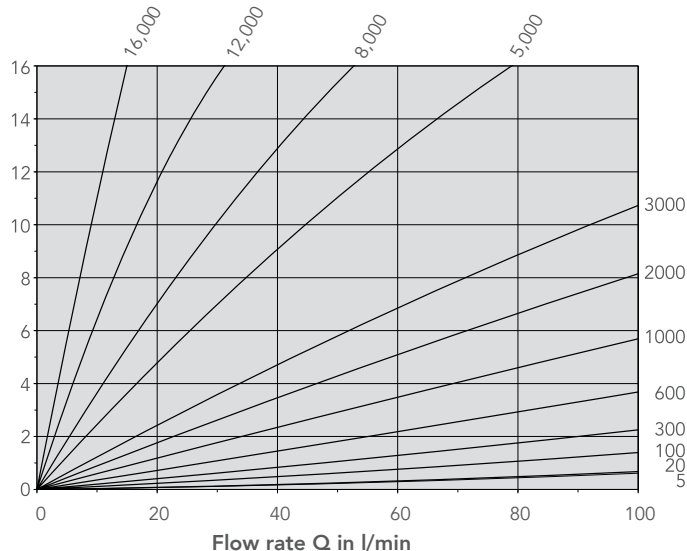

Pressure drop

I Ball-bearing versions Parameter: Viscosity in mm²/s

VC 16

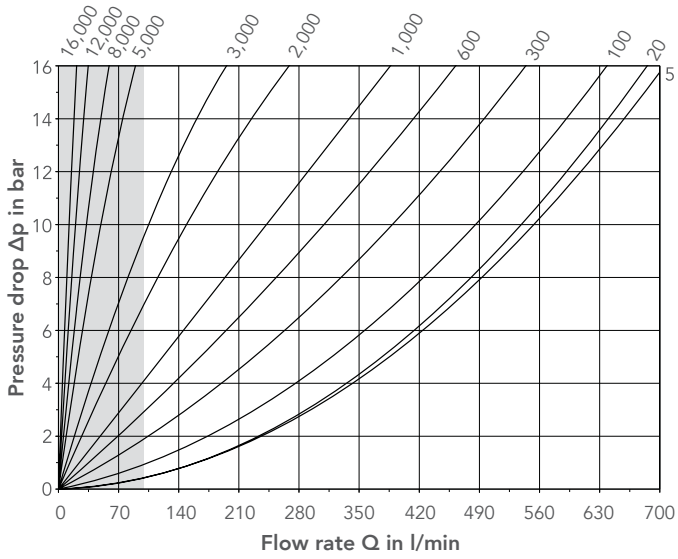

VC 16 (section)

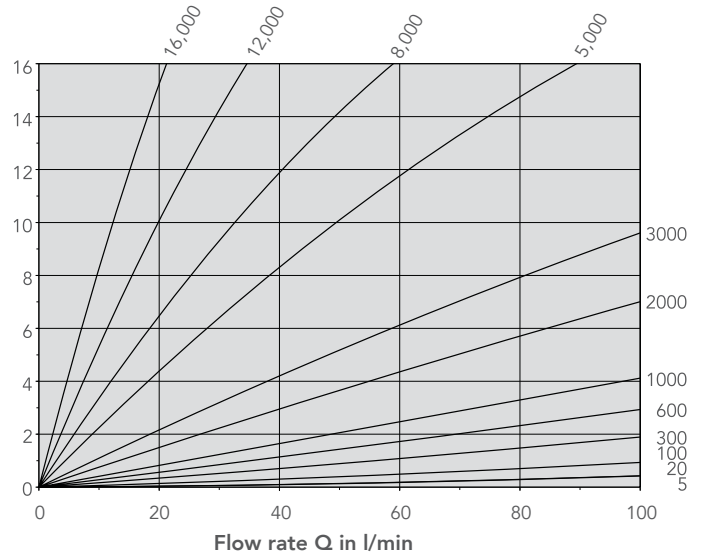

Pressure drop

I Plain-bearing versions Parameter: Viscosity in mm²/s

VC 0.025

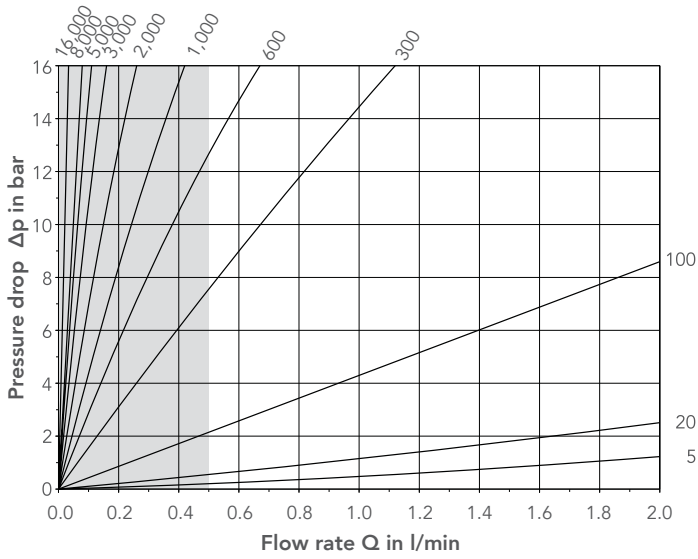

VC 0.025 (section)

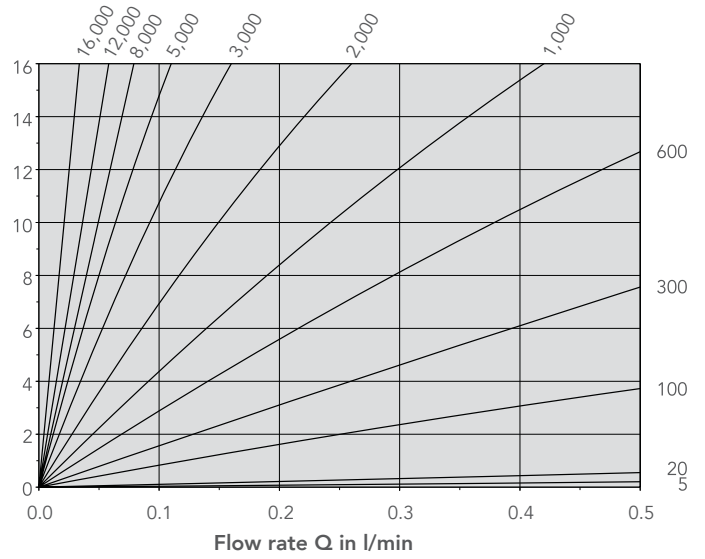

VC 0.1

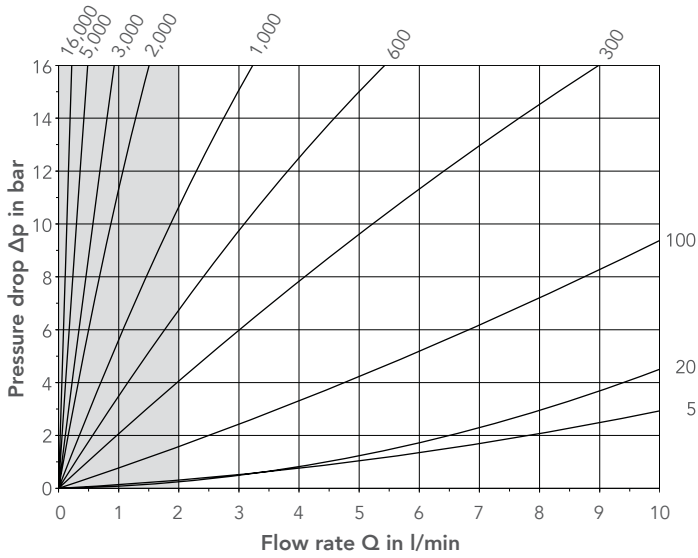

VC 0.1 (section)

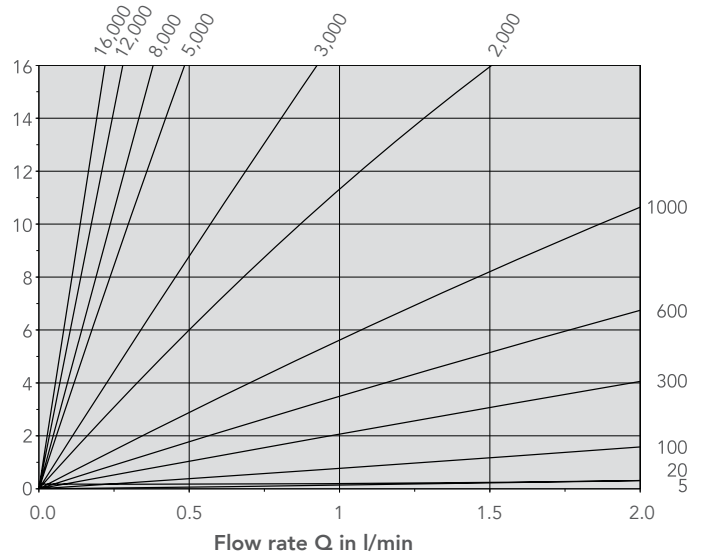

VC 0.2

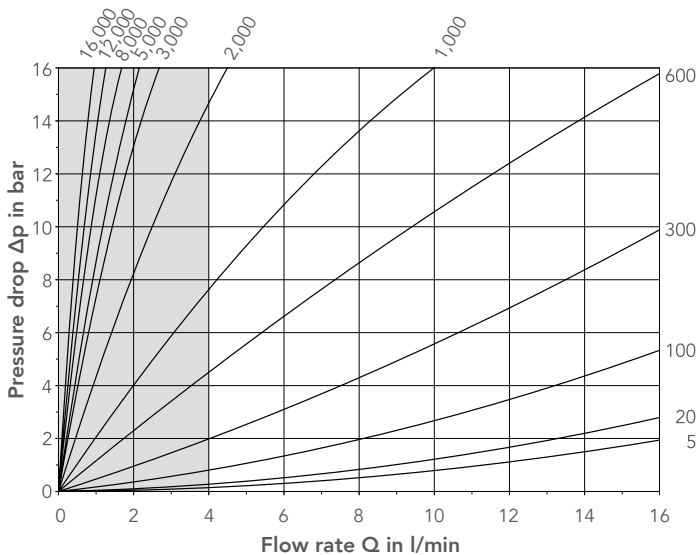

VC 0.2 (section)

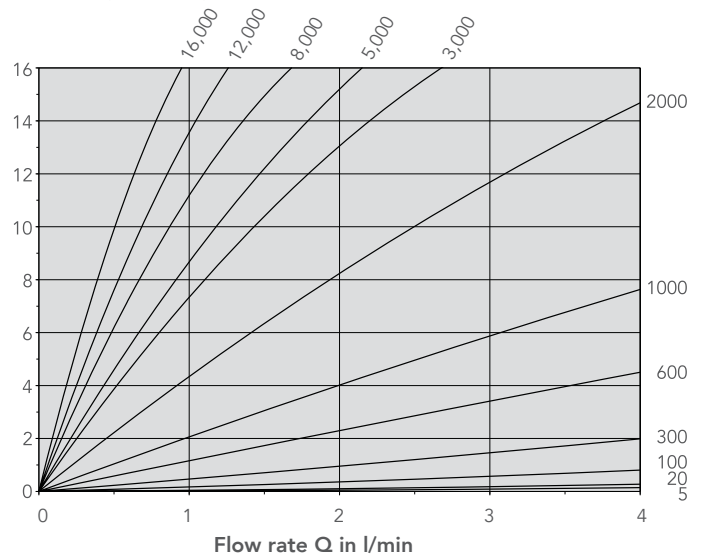

Pressure drop

I Plain-bearing versions Parameter: Viscosity in mm²/s

VC 0.4

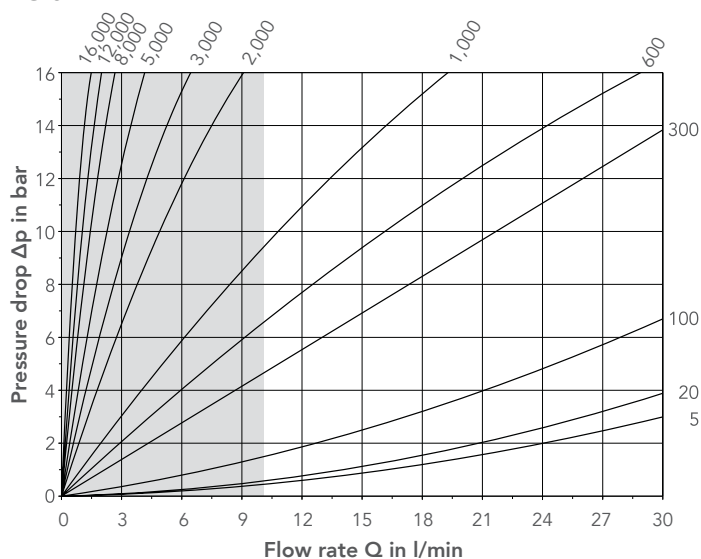

VC 0.4 (section)

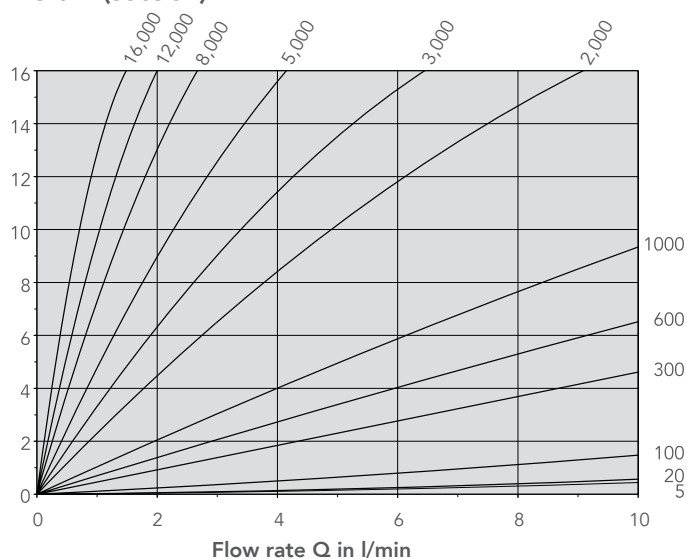

VC 1

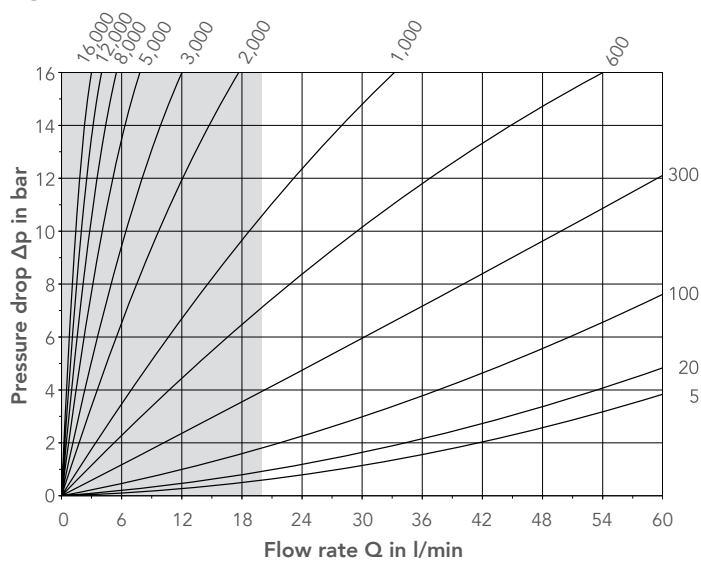

VC 1 (section)

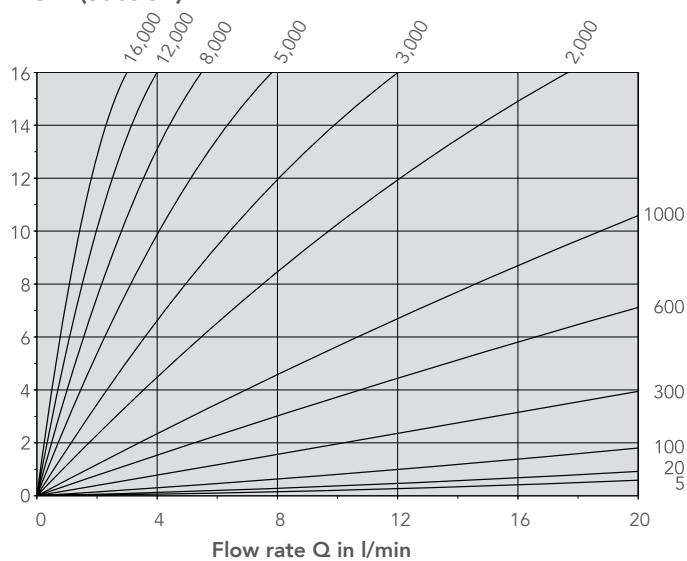

VC 3

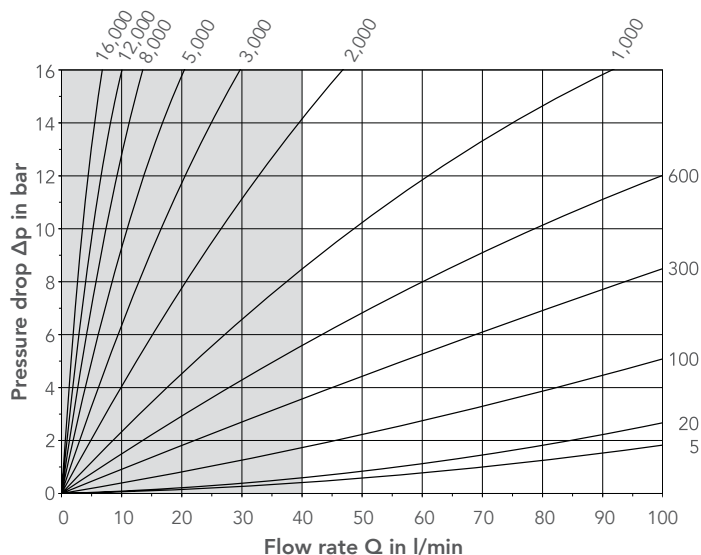

VC 3 (section)

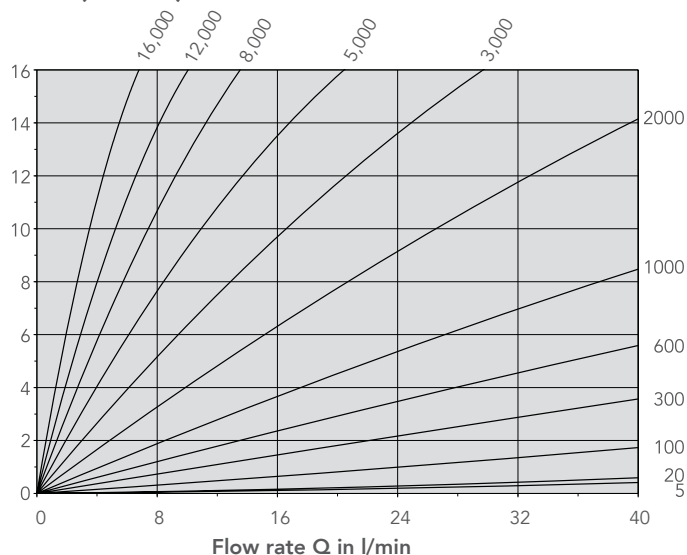

Pressure drop

I Plain-bearing versions Parameter: Viscosity in mm²/s

VC 5

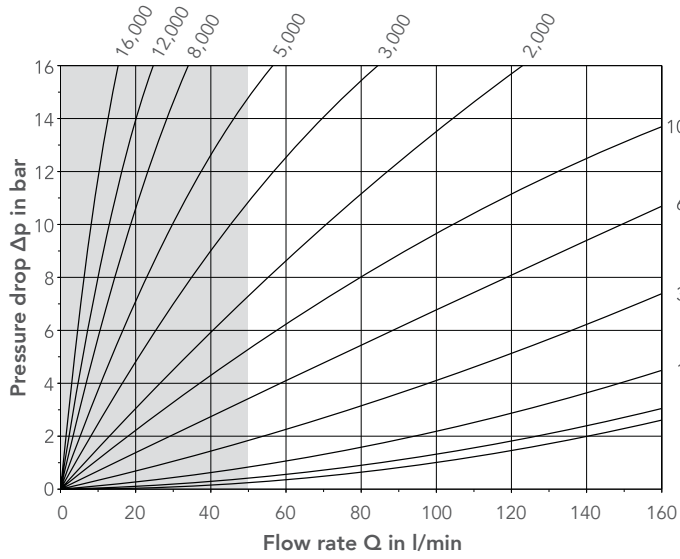

VC 5 (section)

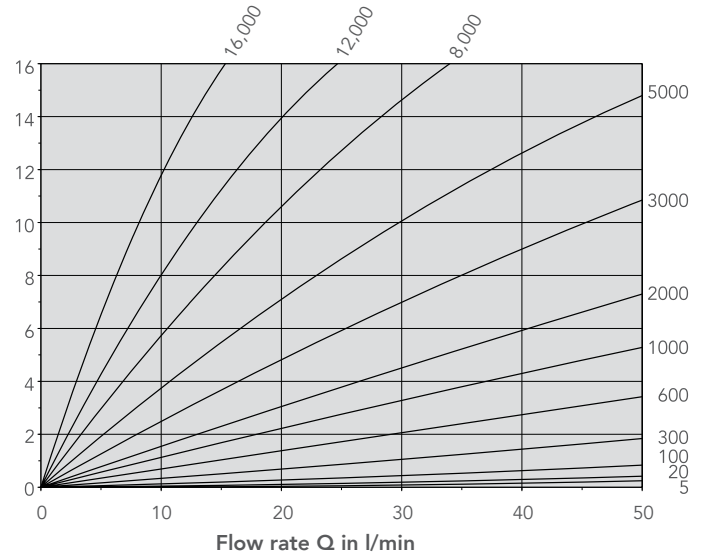

VC technical drawings overview

Versions	Nominal sizes	Electronics versions	Restriction	Page
Spheroidal cast iron version Plate mounting	0.025 ... 5	> standard > high-temperature > ATEX/IECEX > IO-Link > encoder		26
Spheroidal cast iron version Plate mounting	0.025 ... 5	> high-temperature Plus > high-temperature Plus ATEX/IECEX		27
Spheroidal cast iron version Plate mounting	3 and 5	> standard > high-temperature > ATEX/IECEX > IO-Link	only K3	28
Spheroidal cast iron version Plate mounting	3 and 5	> high-temperature Plus > high-temperature Plus ATEX/IECEX	only K3	29
Spheroidal cast iron version Plate mounting	12 and 16	> standard > high-temperature > ATEX/IECEX > IO-Link > encoder		30
Spheroidal cast iron version Plate mounting	12 and 16	> high-temperature Plus > high-temperature Plus ATEX/IECEX		31
Stainless-steel version Plate mounting	0.025 ... 5	> standard > high-temperature > ATEX/IECEX > IO-Link > encoder		32
Stainless-steel version Plate mounting	0.025 ... 5	> high-temperature Plus > high-temperature Plus ATEX/IECEX > low-temperature		33
Stainless-steel version Pipe connection	0.025 ... 5	> standard > high-temperature > ATEX/IECEX > IO-Link > encoder		34

Dimensions

I Spheroidal cast iron version – plate mounting

Electronics versions: standard / high-temperature / ATEX/IECEX / IO-Link / encoder

Nominal size	Dimensions											Tightening torque	Weight
	A	C	D	F	G*	J	K	L	M	N	P	Nm	kg
												M _A	m
VC 0.025	85	10	60	50	101	-	70	40	20	6.7	M 6	14	1.8
VC 0.04	85	9	60	56	107	-	70	40	20	6.7	M 6	14	2.0
VC 0.04 / encoder	85	12	60	48	95	9.65	70	40	20	6.7	M 6	14	2.0
VC 0.1	85	10	60	55	106	-	70	40	20	9	M 6	14	2.5
VC 0.2	85	13	60	57	108	-	70	40	20	9	M 6	14	2.0
VC 0.2 / encoder	85	13	60	57	104	10.80	70	40	20	9	M 6	14	2.0
VC 0.4	100	17	90	63	114	-	80	38	34	16	M 8	35	3.7
VC 1	120	13	95	72	123	15.50	84	72	35	16	M 8	35	5.2
VC 1 / encoder	120	16	95	69	116	18.20	84	72	35	16	M 8	35	5.4
VC 3**	170	18	120	89	140	46.50	46	95	50	25	M 12	120	9.0
VC 5**	170	22	120	105	156	46.50	46	95	50	25	M 12	120	13.0

* electronics version H: plus 12 mm

electronics version X: plus 6 mm

** does not apply to K3 specification. Dimensions VC 3/VC 5 – see page 29 for K3.

Version with Hirschmann plug

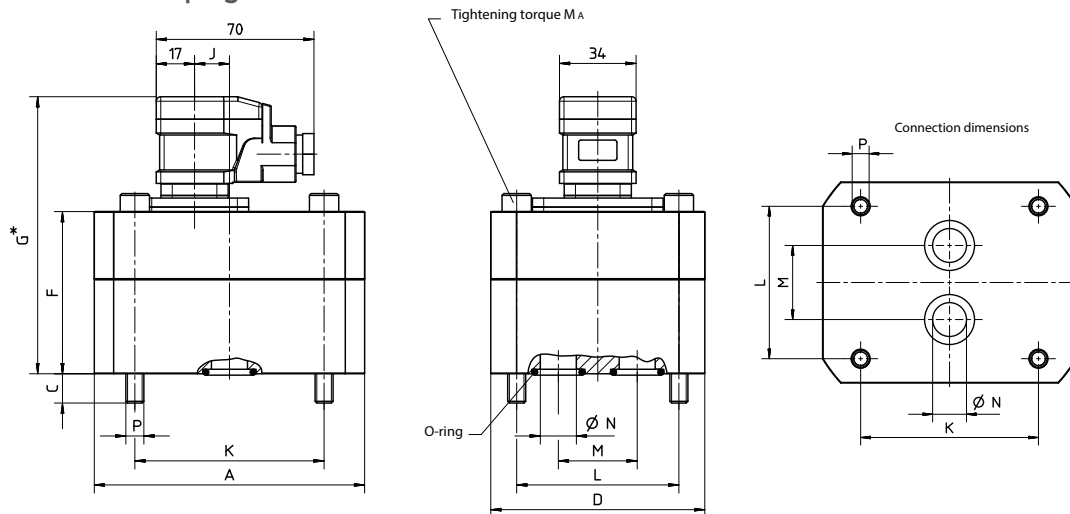

Version with encoder

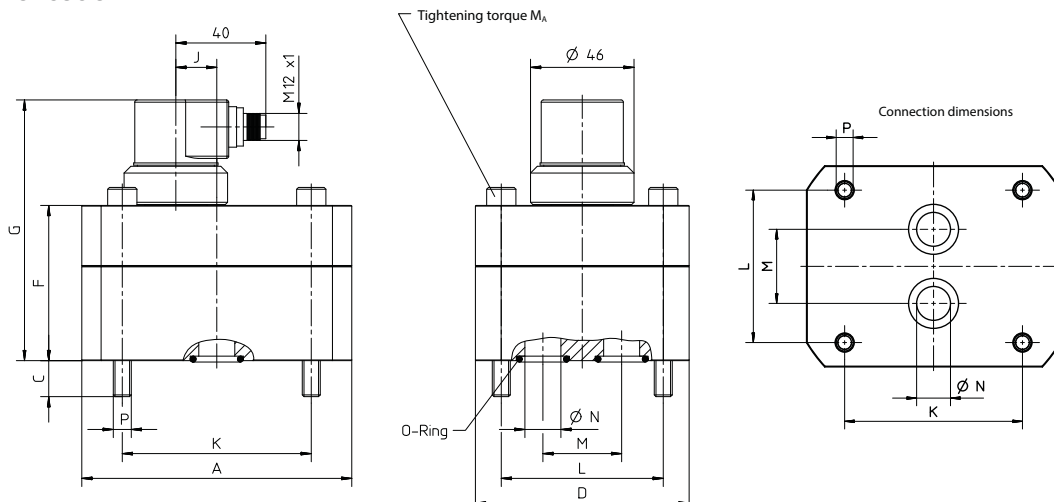

Dimensions in mm

Dimensions

I Spheroidal cast iron version – plate mounting

Electronics versions: high-temperature PLUS / high-temperature Plus ATEX/IECEX

Nominal size	Dimensions											Tightening torque	Weight
	A	C	D	F	G	J	K	L	M	N	P	Nm	kg
												M _A	m
VC 0.025	85	10	60	50	87	-	70	40	20	6.7	M 6	14	1.8
VC 0.04	85	9	60	56	93	-	70	40	20	6.7	M 6	14	2
VC 0.1	85	10	60	55	92	-	70	40	20	9	M 6	14	2.3
VC 0.2	85	13	60	57	94	-	70	40	20	9	M 6	14	2
VC 0.4	100	17	90	63	100	-	80	38	34	16	M 8	35	3.7
VC 1	120	13	95	72	109	18.5	84	72	35	16	M 8	35	5.2
VC 3	170	18	120	89	126	11	46	95	50	25	M 12	120	9
VC 5	170	22	120	105	142	11	46	95	50	25	M 12	120	13

Connection dimensions

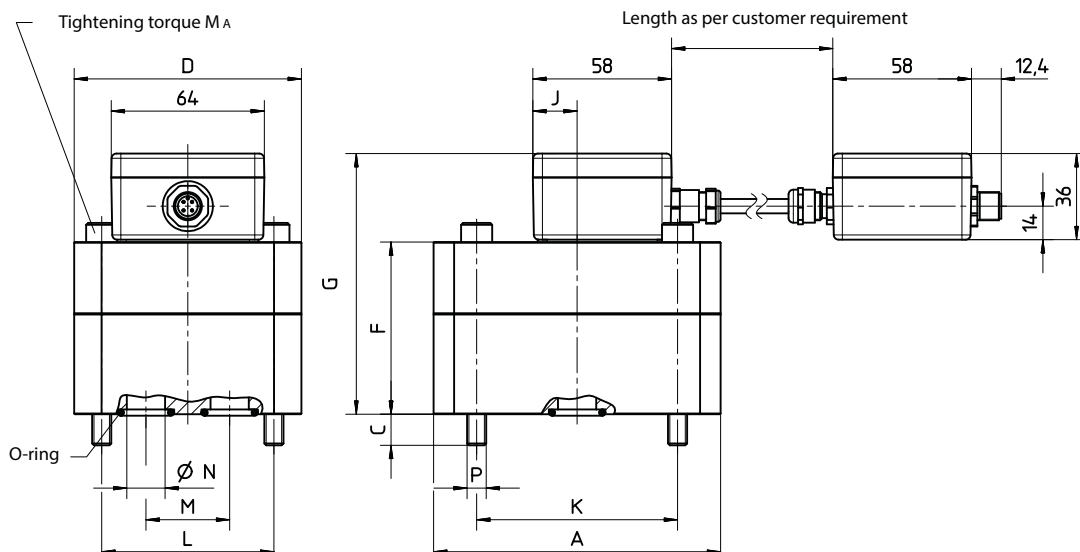
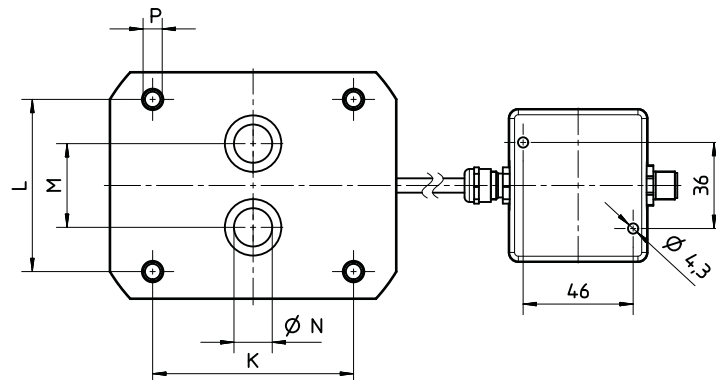

Dimensions

I Spheroidal cast iron version – plate mounting – specification K3

Electronics versions: standard / high-temperature / ATEX/IECEX / IO-Link

Nominal size	Dimensions										Tightening torque	Weight
	C	D	F	G*	J	K	L	M	N	P	Nm	kg
											M _A	m
VC 3	23	179	99	150	46.5	46	95	50	25	M 12	145	16.3
VC 5	22	179	115	166	46.5	46	95	50	25	M 12	145	18.9

* electronics version H: plus 12 mm

Connection dimensions

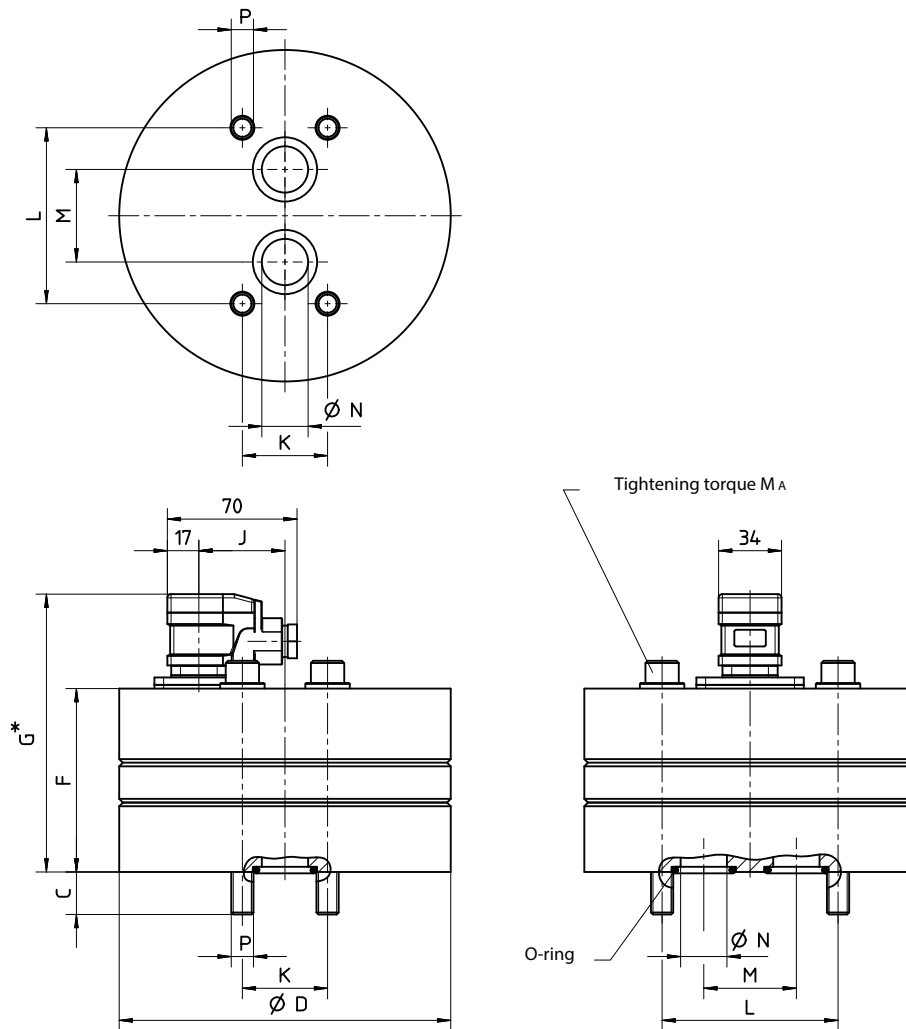

Dimensions

I Spheroidal cast iron version – plate mounting – specification K3

Electronics versions: high-temperature Plus / high-temperature Plus ATEX/IECEX

Nominal size	Dimensions										Tightening torque	Weight
	C	D	F	G	J	K	L	M	N	P	Nm	kg
											M _A	m
VC 3	23	179	99	136	-	46	95	50	25	M 12	120	16.3
VC 5	22	179	115	152	11	46	95	50	25	M 12	120	18.9

Connection dimensions

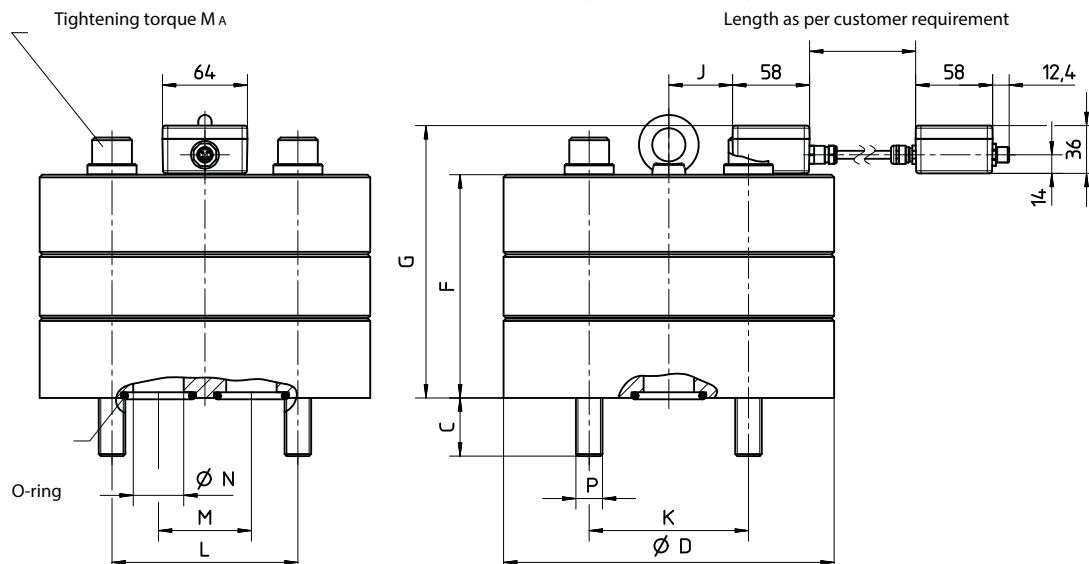
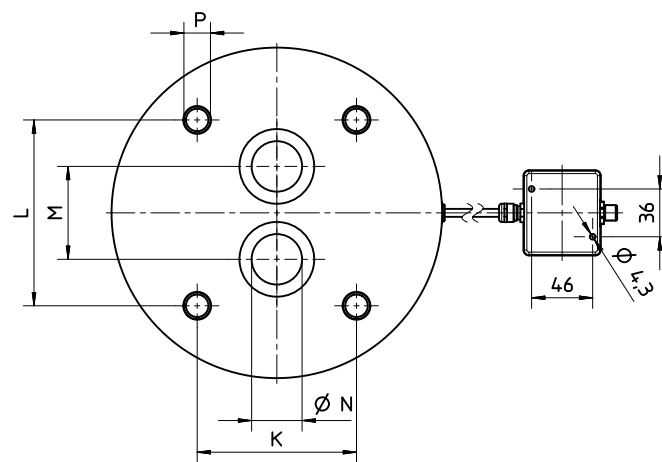

Dimensions

I Spheroidal cast iron version – plate mounting

Electronics versions: standard / high-temperature / ATEX/IECEX / IO-Link / encoder

Nominal size	Dimensions										Tightening torque	Weight
	C	D	F	G*	J	K	L	M	N	P	Nm	kg
											M _A	m
VC 12	44	249	168	219	78	120	140	70	38	M 20	400	53.5
VC 16	38	249	184	235	78	120	140	70	38	M 20	400	57.4

* electronics version H: plus 12 mm
electronics version X: plus 6 mm

Connection dimensions

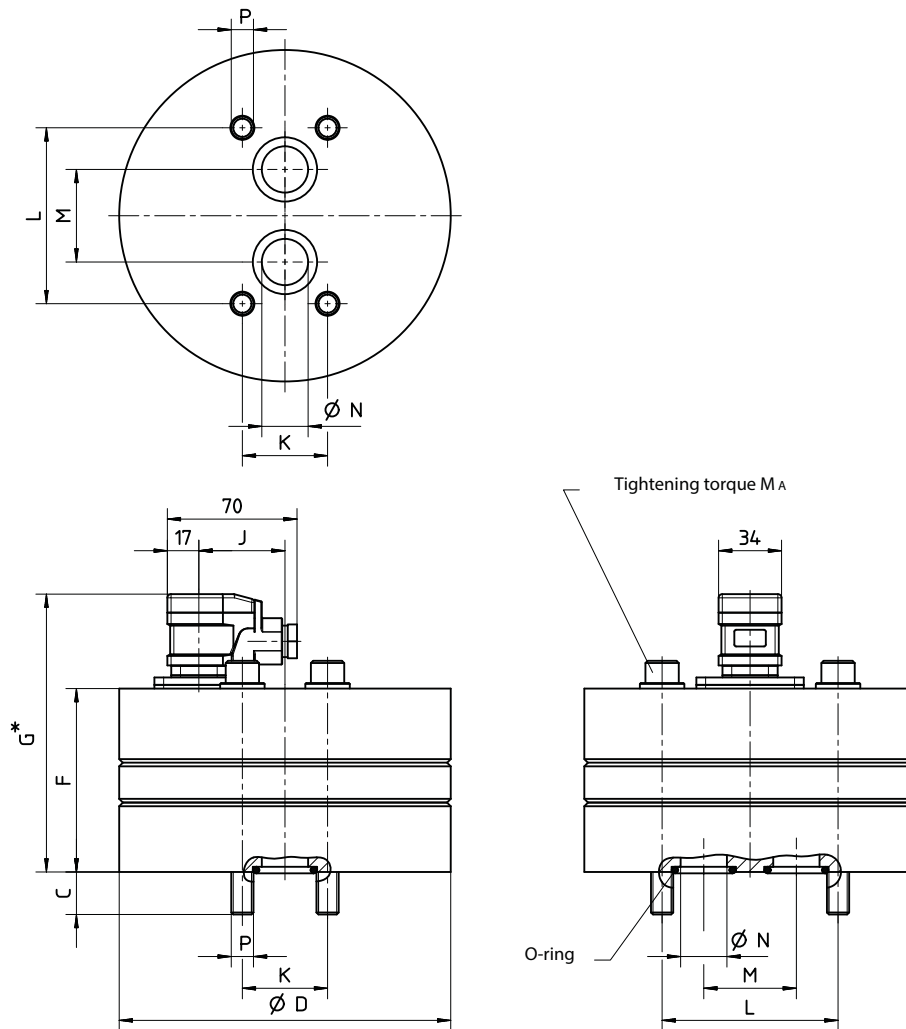

Dimensions

I Spheroidal cast iron version – plate mounting – specification K3

Electronics versions: high-temperature Plus / high-temperature Plus ATEX/IECEX

Nominal size	Dimensions										Tightening torque	Weight
	C	D	F	G	J	K	L	M	N	P	Nm	kg
											M _A	m
VC 12	44	249	168	205	48	120	140	70	38	M 20	400	53.5
VC 16	38	249	184	221	48	120	140	70	38	M 20	400	57.4

Connection dimensions

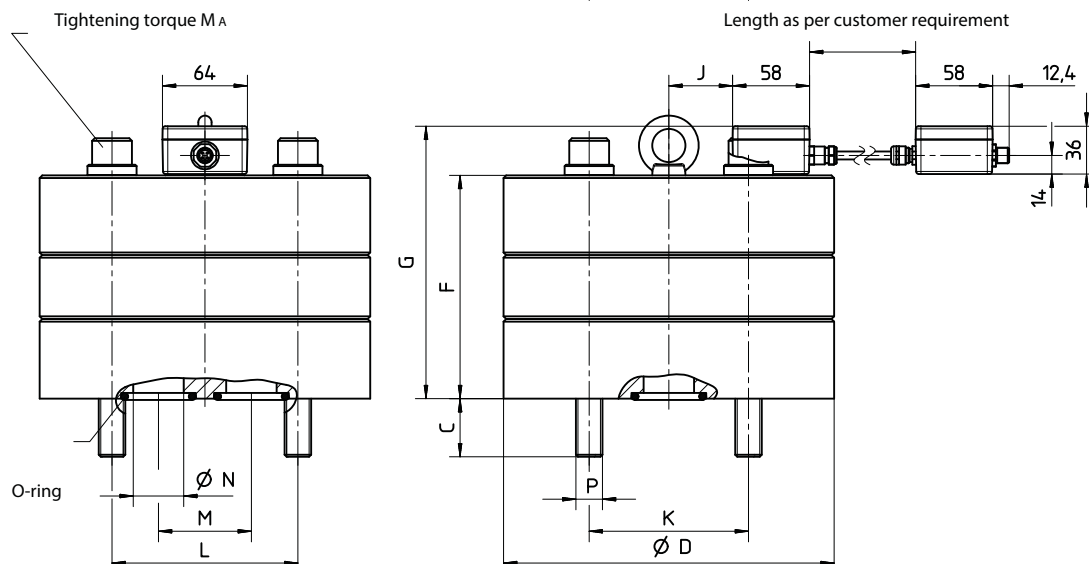
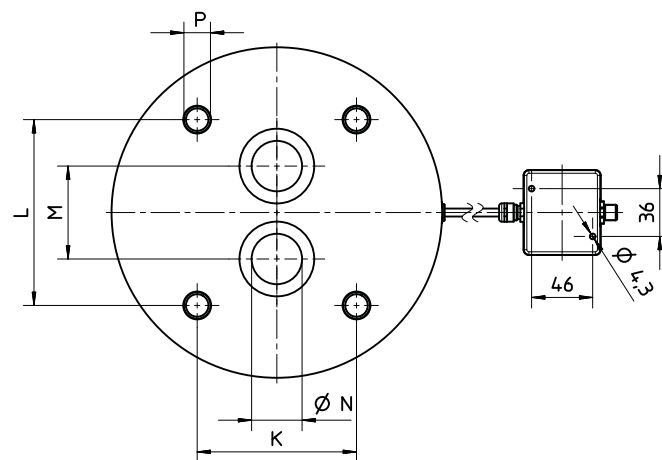

Dimensions

I Stainless steel version – plate mounting

Electronics versions: standard / high-temperature / ATEX/IECEx / IO-Link

Nominal size	Dimensions										Tightening torque	Weight
	C	D	F	G*	J	K	L	M	N	P	Nm	kg
											M _A	m
VC 0.025	10	94	55	106	-	70	40	20	6.7	M 6	14	3
VC 0.04	9	94	56	107	-	70	40	20	6.7	M 6	14	3
VC 0.1	10	94	55	106	-	70	40	20	9	M 6	14	3
VC 0.2	13	94	57	108	-	70	40	20	9	M 6	14	3.1
VC 0.4	17	118	63	114	-	80	38	34	16	M 8	35	4.8
VC 1	13	124	72	123	15.5	84	72	35	16	M 8	35	7
VC 3	18	170	89	140	46.5	46	95	50	25	M 12	120	15.9
VC 5	22	170	105	156	46.5	46	95	50	25	M 12	120	18.7

* electronics version H: plus 12 mm
electronics version X: plus 6 mm

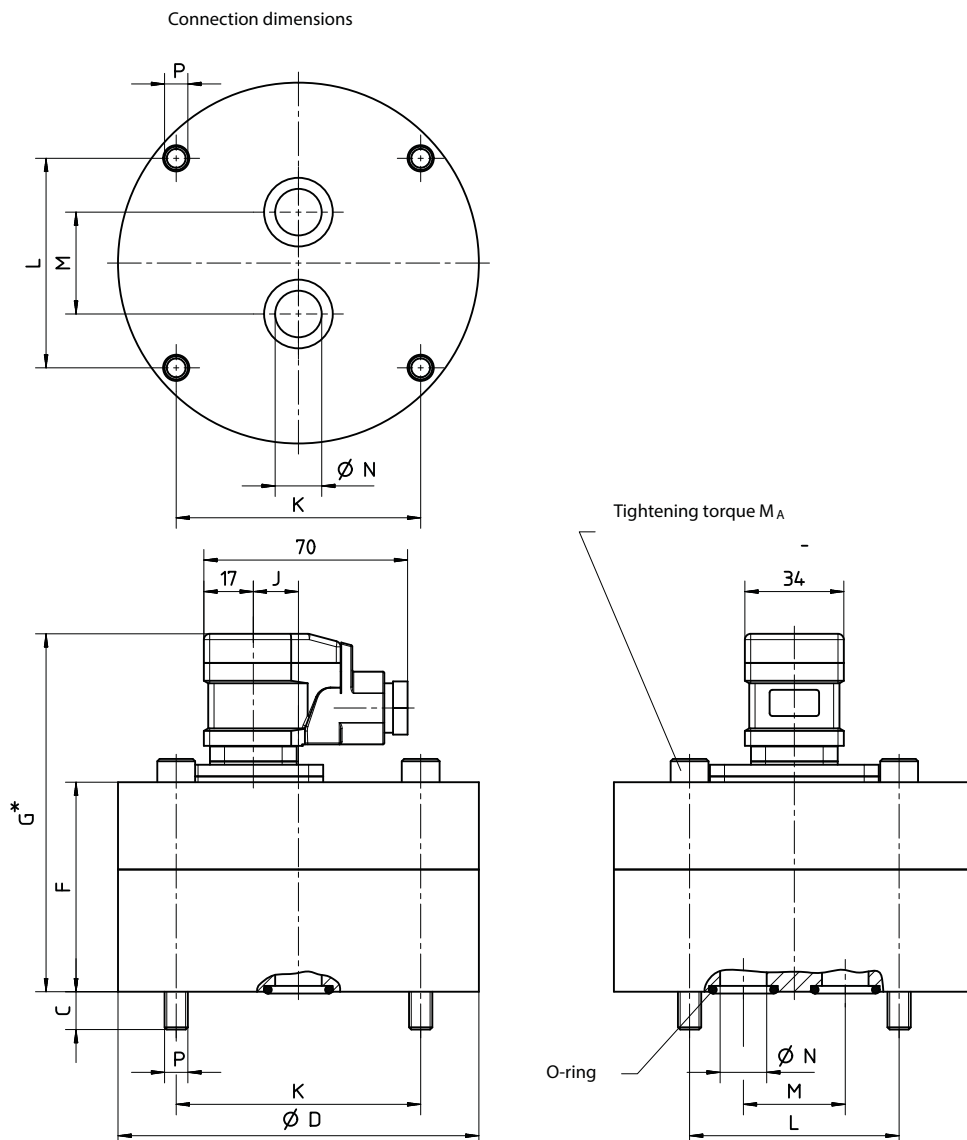

Dimensions

I Stainless steel version – plate mounting

Electronics versions: high-temperature Plus / high-temperature Plus ATEX/IECEX / low-temperature

Nominal size	Dimensions										Tightening torque	Weight
	C	D	F	G	J	K	L	M	N	P	Nm	kg
											M _A	m
VC 0.025	10	94	55	92	-	70	40	20	6.7	M 6	14	3
VC 0.04	9	94	56	93	-	70	40	20	6.7	M 6	14	3
VC 0.1	10	94	55	92	-	70	40	20	9	M 6	14	3
VC 0.2	13	94	57	94	-	70	40	20	9	M 6	14	3.1
VC 0.4	17	118	63	100	-	80	38	34	16	M 8	35	4.8
VC 1	13	124	72	109	18.5	84	72	35	16	M 8	35	7
VC 3	18	170	89	126	11	46	95	50	25	M 12	120	15.9
VC 5	22	170	105	142	11	46	95	50	25	M 12	120	18.7

Connection dimensions

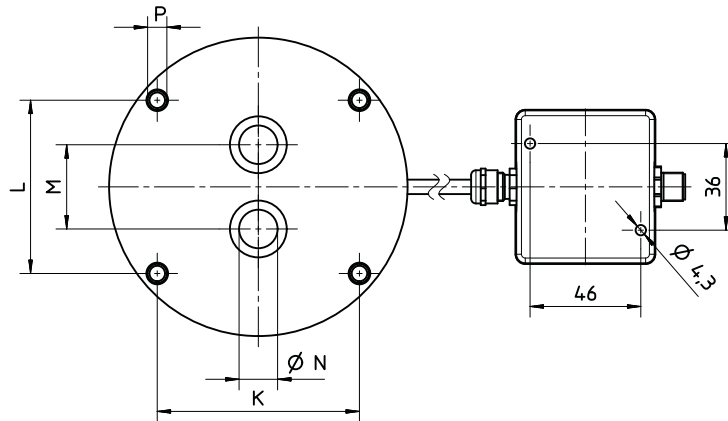

Length as per customer requirement

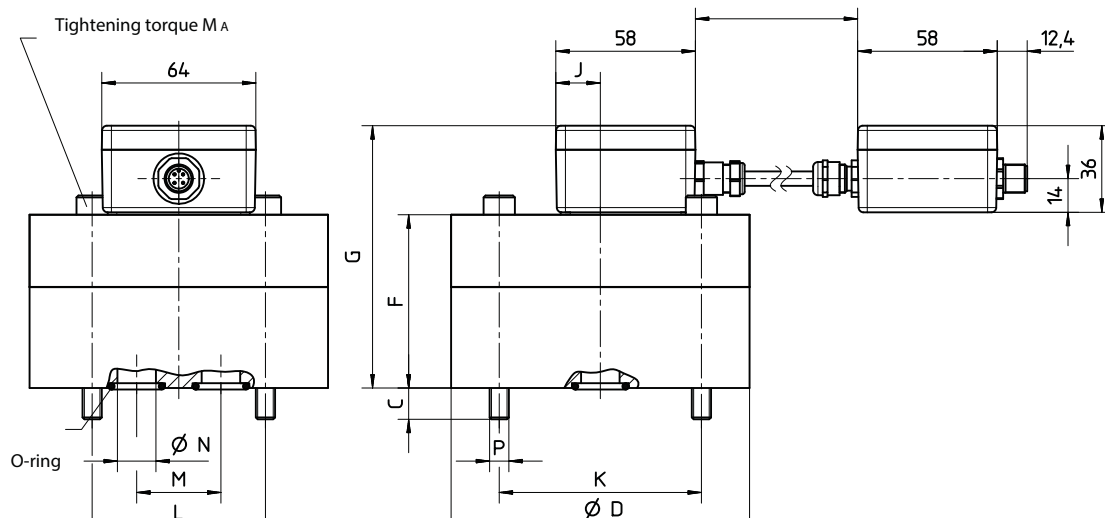

Dimensions

I Stainless steel version – pipe connection

Electronics versions: standard / high-temperature / ATEX/IECEX / IO-Link

Nominal size	Dimensions												Weight
	A	B	C	D	E	F	G*	H	J	K	L	R	kg m
VC 0.025	G 1/8	9	17	94	90	55	106	15	-	70	40	6.7	3
VC 0.04	G 1/4	13	21	94	90	56	107	15	-	70	40	6.7	3
VC 0.1	G 3/8	13	25	94	90	55	106	15	-	70	40	6.6	3
VC 0.2	G 3/8	13	25	94	90	57	108	16	-	70	40	6.5	3.1
VC 0.4	G 1/2	15	29	118	114	63	114	17.5	-	80	38	9	4.8
VC 1	G 1/2	15	29	124	120	72	123	22	15.5	84	72	9	7
VC 3	G 1	19	51.5	170	162	89	140	30	46.5	46	95	13	15.9
VC 5	G 1	19	42	170	162	105	156	30	46.5	46	95	13	18.7

* electronics version H: plus 12 mm
electronics version X: plus 6 mm

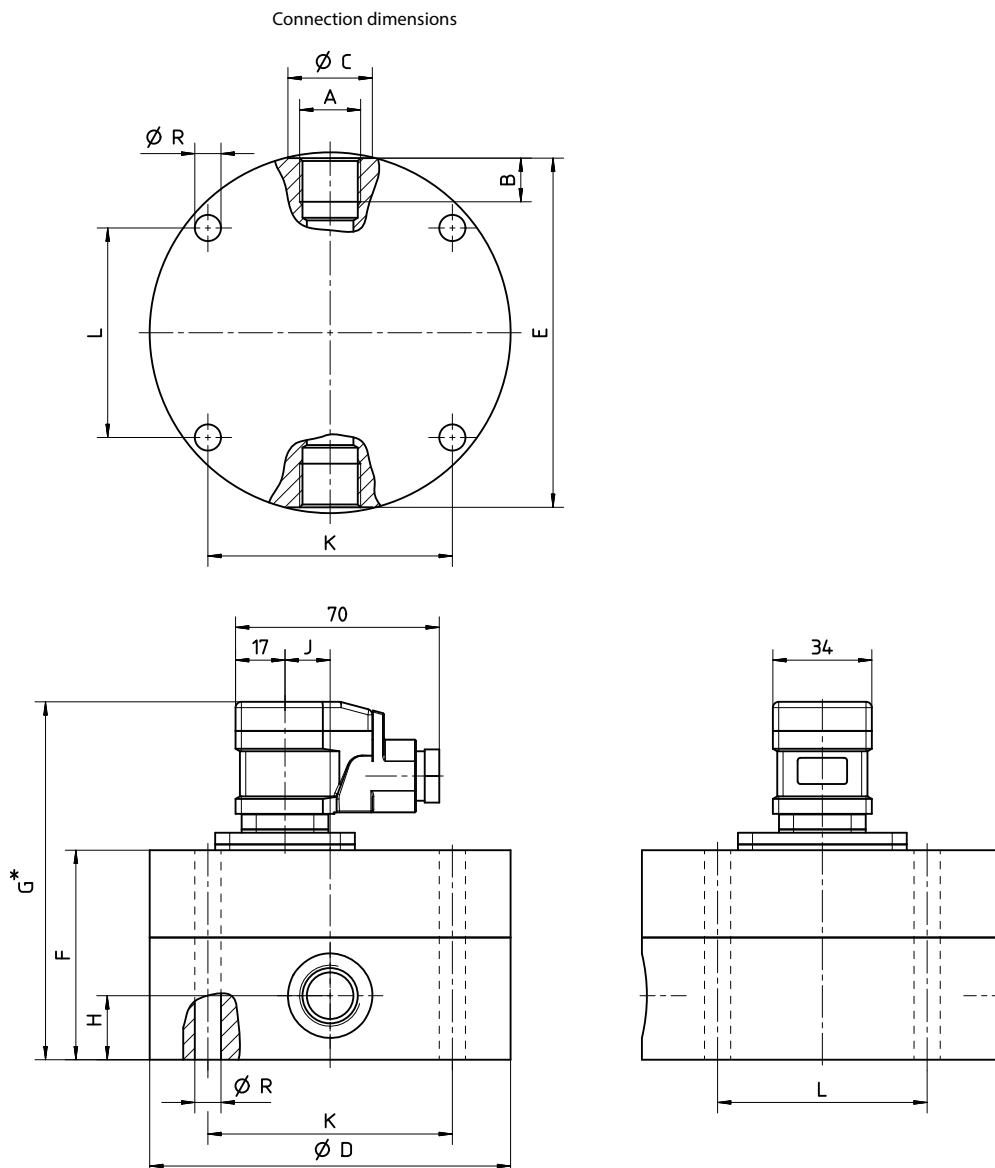

Dimensions in mm

Dimensions

I Connection plates (cast iron) with lateral threaded connection

Ordering code	Dimensions																		Weight
	e	A	B	C	E	F	G	H	J	K	L	M	N	P	R	c	d	f	kg m
MVC 0,2 R3 B05*	G 3/8	85	90	35	65	76	7	11	7	70	40	20	6.5	M 6/14 deep	17	0.7	25	13	1.8
MVC 0,2 R3 C05*	G 1/2	85	90	35	65	76	7	11	7	70	40	20	6.5	M 6/14 deep	17.5	0.7	29	15	1.7
MVC 0. R1 C09	G 1/2	100	110	37	86	96	7	11	7	80	38	34	16	M 8/18 deep	18.5	0.7	29	15	2.7
MVC 0. R1 D09	G 3/4	100	110	42	86	96	7	11	7	80	38	34	16	M 8/18 deep	21	1	36	17	2.9
MVC 1 R2 C05	G 1/2	100	120	37	80	106	7	11	7	84	72	35	12	M 8/18 deep	17.5	0.7	29	15	2.9
MVC 1 R3 D05	G 3/4	120	120	42	80	106	7	11	7	84	72	35	13	M 8/18 deep	21	1	36	17	4
MVC 1 R2 E05	G 1	100	120	65	80	106	7	11	8	84	72	35	13	M 8/18 deep	32.5	1	42	19	4.9
MVC 5 R2 E05**	G 1	160	165	80	140	145	9	15	9	46	95	50	25	M 12/24 deep	28	1	42	19	14
MVC 5 R2 G09**	G 1 1/2	170	165	100	140	145	9	15	9	46	95	50	25	M 12/24 deep	42	1	58	23	17.8

* suitable for VC 0.025, VC 0.04, VC 0.1, VC 0.2 and VC with 0.2 encoder

** suitable for VC 3 and VC 5

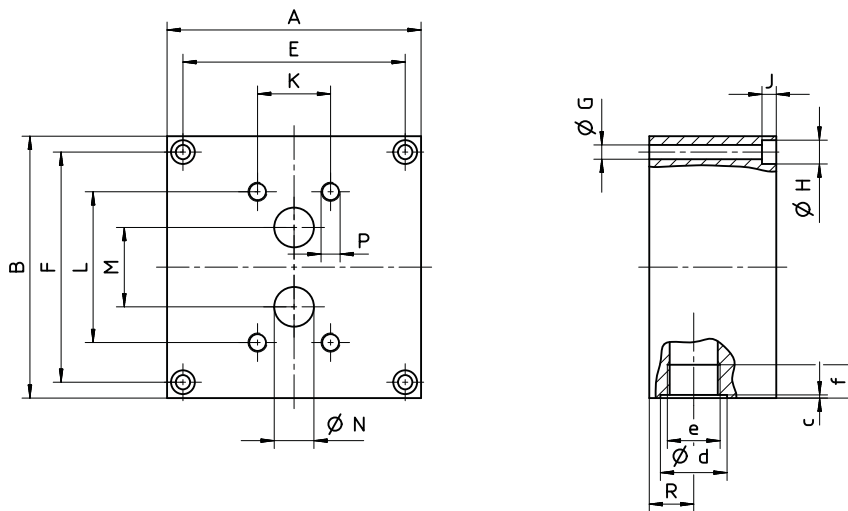

Dimensions

I Connection plates (cast iron) with rear threaded connection

Ordering code	Dimensions																		Weight
	e	A	B	C	E	F	G	H	J	K	L	M	N	P	R	c	d	f	kg m
MVC 0.2 R3 B04*	G 3/8	85	90	35	65	76	7	11	7	70	40	20	6.5	M 6/14 deep	28	0.7	25	13	1.6
MVC 0.4 R1 C08	G 1/2	100	110	37	86	96	7	11	7	80	38	34	16	M 8/18 deep	46	0.7	29	15	2.5
MVC 0,4 R1 D08	G 3/4	100	110	42	86	96	7	11	7	80	38	34	16	M 8/18 deep	52	1	36	17	2.9
MVC 1 R2 C04	G 1/2	100	120	37	80	106	7	11	7	84	72	35	12	M 8/18 deep	50	0.7	29	15	2.7
MVC 5 R2 E04**	G 1	160	165	55	140	145	9	15	9	46	95	50	25	M 12/24 deep	55	1	42	19	9.6

* suitable for VC 0.025, VC 0.04, VC 0.1, VC 0.2 and VC with 0.2 encoder

** suitable for VC 3 and VC 5

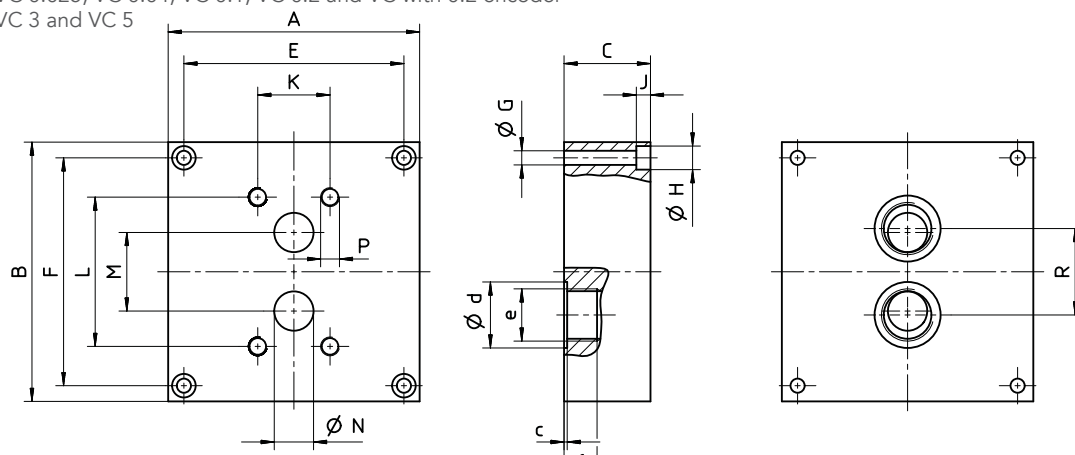

I Connection plates (stainless steel) with lateral threaded connection

Ordering code	Dimensions															Weight
	e	B	C	D	E	G	H	J	K	L	M	N	P	R	f	kg m
MVC 0,2 R4 B11*	G 3/8	85	35	94	75	7	11	7	70	40	20	6.5	M 6/14 deep	18	13	1.7
MVC 1 R3 C11	G 1/2	116	37	124	100	9	15	9	84	72	35	12	M 8/18 deep	19.5	15	3.2
MVC 1 R2 D11	G 3/4	116	42	124	100	9	15	9	84	72	35	12	M 8/18 deep	21	17	3.5
MVC 5 R2 E11**	G 1	158	80	170	140	9	15	9	46	95	50	25	M 12/24 deep	52	19	13.9
MVC 5 R2 G11**	G 1 1/2	158	105	170	140	9	15	9	46	95	50	25	M 12/24 deep	63	23	17.9

* suitable for VC 0.025, VC 0.04, VC 0.1, VC 0.2 and VC with 0.2 encoder

** suitable for VC 3 and VC 5

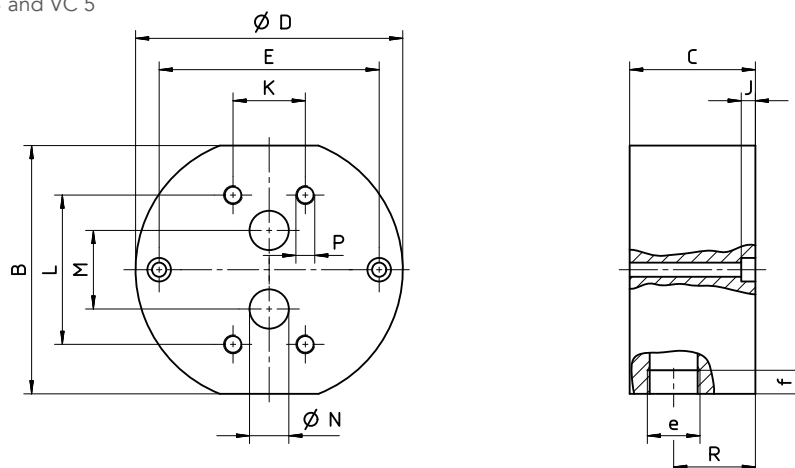

Dimensions in mm

Dimensions

I Connection plates (spheroidal cast iron) with lateral SAE flange connection for VC 3 and 5 in K3 specification

Ordering code	Dimensions																	Weight
	B	C	D	E	F	G	K	L	M	N	P	R	a	b	e	f	kg	
																		m
MVC 5 V1 E09	150	90	180	110	110	M 8/24 deep	46	95	50	25	M 12/24 deep	50	57.2	27.8	25	M 12/24 deep	14.2	

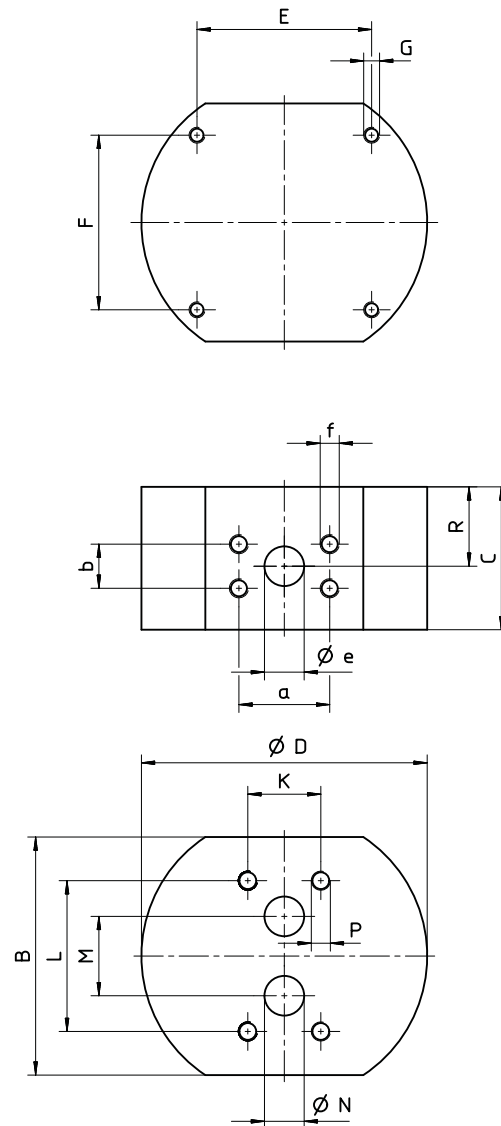

Flow measurement overview

Flow meter	Description	Flow range	Medium temperature range	Maximum pressure
VC	Gear type flow meter	0.001 ... 700 l/min	-60 ... 210°C	480 bar
VCA	Gear type flow meter	0.02 ... 200 l/min	-10 ... 80°C	240 bar
SVC	Screw type flow meter	0.01 ... 3 750 l/min	-40 ... 220°C	480 bar
TM	Turbine flow meter	0.92 ... 66 667 l/min	-30 ... 400°C	400 bar
VOLUMEK	The valve position indicator VOLUMEK is a linking unit consisting of a valve block, volume counter, and display unit.	... 7 l/min	-20 ... 80°C	240 bar
VOLUTRONIC®	The valve position indicator VOLUTRONIC® is the electronic variant of the VOLUMEK system. It indicates the direction of flow by generating two incremental signals.	0.16 ... 16 l/min	-30 ... 80°C	200 bar

Electronics	Description	Applications
SD 1	The plug-on display SD 1 is a universal local indicator for all volume counter series (VC, VCA, SVC, TM) with a DIN 43650-A valve plug connection. The display optionally shows the flow or the volume.	Volume measurement Flow measurement
AS 8	The AS 8 processes the output signals of the flow meters. The unit filters, transforms and computes the input signals into the physical parameters flow or volume, and displays them.	Measures volume, flow, mixing ratio, flexibility ratio, stroke, sums, and differences Controls flow, mixing ratio and revolutions Dosing
ASR 14	The ASR 14 integrates control, operation and visualisation functions. The programming of the ASR 14 is tailored to customer requirements.	like AS 8 – customisable
ASR 30	The ASR 30 is a control unit which can be operated via touch screen. In addition, the unit can be expanded with manual operating units. This allows the implementation of numerous fluid technology applications. Standardised programs are available for various applications. The programming of the ASR 30 can be optimised to match to the respective application.	like AS 8 – customisable

Notes

I Gear pumps

Low-pressure and high-pressure gear pumps for lubricating oil, hydraulic, process, and test bench applications, fuel and metering systems.



I Flow measurement

Gear, turbine and screw type flow meters, electronics for volume and flow, metering and consumption in the chemical industry; hydraulic, process and test bench technology.



I Hydraulics

Single and multi-stage high-pressure gear pumps, gear motors and valves for construction machinery, municipal vehicles, agricultural vehicles, special-purpose vehicles and truck bodies.



I Valves

Cetop valves for all requirements of stationary and mobile applications. Pressure, switch and check valves with pipe connection for high flow rates. Special valves.



KRACHT®

KRACHT GmbH · Gewerbestraße 20 · 58791 Werdohl, Germany
 Phone +49 2392.935 0 · Fax +49 2392.935 209
 E-Mail info@kracht.eu · Web www.kracht.eu